



CANADA

FULL LINE CATALOGUE

*Framing • Structural • Cabinetry • Finishing • Specialty*

# GRK



## FASTENERS



***Drive with Speed, Quality and Confidence***

## What Makes Us ÜberGrade?



RECESSED  
STAR DRIVE

CEE THREAD™

W-CUT™

ZIP-TIP™

*Drive with Speed, Quality and Confidence*



Zero Stripping, with (6) points of contact

Enlarges hole to reduce splitting and install torque

Low torque, smoother drive,  
and reduce splitting

No pre-drilling,  
faster penetration  
and reduce splitting



*Case Hardened Steel for high tensile,  
torque and shear strength.*

*Full breadth of line meeting remodeling and new  
construction fastening needs for: Decks, Framing,  
Trim, Cabinets, Windows, Doors and more.*

**BUILDING CODE APPROVED**—for structural use in treated lumber. GRK screws have been evaluated for structural and AC257 corrosion resistance to be in compliance with IBC/IRC specifications. That's why all our fasteners come with a limited lifetime warranty, so you can rest assured your installations will last the life of your project.

# Table of Contents



- What Make Us ÜberGrade? ..... G 2
- Selection Guide..... G 4
- Deck Elite ..... G 6
- R4™ Multi-Purpose Framing Screws..... G 8
- RSS™ Rugged Structural Screws..... G 24
- Conversion Guide "Convert from a LAG screw to GRK RSS Fasteners" ..... G 26
- Kameleon™ Composite Deck Screws ..... G 32
- Fin/Trim™ Finishing Trim Head Screws..... G 34
- RT™ Composite Exterior Trim Screws..... G 36
- Low Profile™ Cabinet Screws..... G 38
- Top Star™ Adjustable Shim Screws..... G 40
- Caliburn™ Concrete Screws ..... G 42
- Selection Guide (Star Drive Bits, Crown/Bit and Magnetic Bit Holder) ..... G 44
- High Impact Merchandisers Designed to Drive Sales ..... G 45
- RSS™ Technical Fastener Data Performance Tables..... G 46
- R4™, Trim™, Kameleon™ Technical Fastener Data Performance Tables..... G 50
- Liability and Warranties ..... G 54

## Fastener Selection Guide and Quick Reference Product Locator

Always build your project according to current ICC (International Code Council) specifications. GRK's Climatek™ coating meets or exceeds standards, including AC257, for use in various type of preservative treated wood. Please view ICC Report #ESR-2442, ESR-3201 and ESR-3251 for more details. Visit <http://www.grkfasteners.ca/index.php/en/techdata/code-approvals>.

No pre-drilling required for most GRK products, unless required or specified by building material. Always place deck boards with outer edge of growth rings facing up (bark side up). Do not use deck cleaners which contain bleach with coated metals. Consult building material supplier's/manufacturer's recommendations for exact instructions. Decking screws should be countersunk 1/8".



### DECK ELITE

GRK's newest product, Deck Elite™ was designed with the Pro in mind and for high volume deck building for ACQ Material. The Fast Bite Tip allows for immediate engagement with deck boards. The W-Cut reduces torque for faster drive and ease of install. The tan colour matches perfectly with most commonly used deck boards, resulting in a clean finish.

Deck Elite™ screws feature a corrosion resistant coating that is backed by its lifetime guarantee against rust. Generic Screws will not come anywhere close to the Deck Elite™ coating.

Not approved by AC257 nor ICC.



### R4™ MULTI-PURPOSE FRAMING SCREWS:

Frame with ease and confidence. Multi-use screw for wood, particle board, sheet metal, cement fibre board, laminate and wood decking and melamine. They are self tapping eliminating pre-drilling featuring a countersinking head with cutting teeth, W-Cut™ for reducing splitting, CEE Thread™ for no splitting, reducing install torque and our Climatek™ AC257 code approved coating.

For Southern Yellow Pine use #10. For use in all applications including pressure treated lumber.

They are ESR code approved under ICC Report ESR-3201.



### RSS™ RUGGED STRUCTURAL SCREWS:

Speedy lag bolt alternative with Immense drawing power. Ideal for use anywhere you would use a traditional lag screw and more, but with no pre-drilling required. For use in all applications including pressure treated lumber. They are self tapping eliminating pre-drilling featuring a washer head with cutting teeth, W-Cut™ for reducing torque, CEE Thread™ for no splitting, reducing install torque and our Climatek™ AC257 code approved coating. They are ESR code approved under ICC Report ESR-2442.

**NEW! RSS™ Black:** *Designed for an architectural finish*

**RSS™ JTS:** *Joist & Truss Fastener: Used for joists and trusses.*

**RSS™ LTF:** *Timber Frame Fastener: Designed specifically for the Log Home & Timber frame market.*



### KAMELEON™ COMPOSITE DECK SCREWS:

Heads blend in with decking with no mushrooming effect. Use in plastic or composite decking. They come in a variety of deck matching colours of which Grey, Brown and Tan are approved for use with Trex Select™ deck boards.

The Kameleon screws are self tapping featuring fibre trapping rings, a countersinking head with cutting teeth, CEE Thread™, W-Cut™ threads for reduced torque and our Climatek™ AC257 code approved coating. They are ESR code approved under ICC Report ESR-3201.

## Fastener Selection Guide and Quick Reference Product Locator

### FIN/TRIM™ TRIM HEAD SCREWS:

Smallest head on the market for a clean finish. Perfect for all interior and exterior finishing applications including deck rails, exterior wood trim, stairs, banisters, window and door trim, base boards, crown moulding and joining cabinets. For use in all applications including pressure treated lumber.

They are self-tapping eliminating pre-drilling featuring the W-Cut™ threads for reduced torque, and our Climatek™ AC257 code approved coating. They are ESR code approved under ICC Report ESR-3201.



### RT COMPOSITE™ TRIM HEAD SCREWS:

Reverse thread design prevent mushrooming for a clean finish. Engineered for use in exterior applications including classic composite trim and decking, PVC trim and moulding. For use in all applications including pressure treated lumber. RT™ Composite Trim screws are self-tapping eliminating pre-drilling featuring the W-Cut™ threads for reduced torque, and our Climatek™ AC257 code approved coating. They are ESR code approved under ICC Report ESR-3201.



### LOW PROFILE CABINET™ SCREWS:

Built in washer head presses in flush against any material. Used for cabinet and vinyl siding installation. These unique screws are thin enough to prevent most material splitting, while providing sufficient strength to guarantee a secure installation.

They are self tapping eliminating pre-drilling featuring the W-Cut™ threads for reduced torque and our Climatek™ AC257 code approved coating.



### TOP STAR™ SHIM SCREWS:

For plumb installation of wooden door and window frames. No more shims! Other uses include cabinets, insulation, paneling and built-in-wall units.

The two-piece "unique screw within a screw" design reduces labour when installing wooden doors or windows. A unique 2 piece crown/bit allows for quick and easy driving.



### CALIBURN™ SCREWS:

Heavy duty concrete and masonry fastener. For attaching a variety of materials and fixtures to concrete. Easy driving high carbon steel allows the screws to create threads while being driven into the concrete. Proper pre-drilling with correct drill bit required. Caliburn™ screws are Climatek™ AC257 code approved coating.

**Caliburn Screw:** Tapered concrete screw for securing wood.

**Caliburn™ PH Screw:** Pan head concrete screw for a more aesthetic look

**Caliburn™ XL Screws:** Washer head style concrete screw for strong connections



**Fast Start, Fast Drive, Ideal Finish**



**DESCRIPTION/SUGGESTED SPECIFICATIONS**

**Decking Screws—**

GRK's newest product, Deck Elite™ was designed with the Pro in mind and for high volume deck building for ACQ Material. The Fast Bite Tip allows for immediate engagement with deck boards. The W-Cut reduces torque for faster drive and ease of install. The tan colour matches perfectly with most commonly used deck boards, resulting in a clean finish.

**ÜberGrade™**



Deck Elite™ screws feature a corrosion resistant coating that is backed by its lifetime guarantee against rust. Generic Screws will not come anywhere close to the Deck Elite™ coating.

**ADVANTAGES**

- **Recessed Star Drive:** Zero Stripping, with 6 points of contact.
- **CEE Thread:** Enlarges hole to reduce splitting, install torque.
- **W-Cut™:** Low torque, smoother drive, reduce splitting.
- **Zip-Tip™:** No pre-drilling, faster penetration, reduce splitting.
- **Cutting Pockets:** provide a clean hole, reduces splitting, and bore with precision.
- **Case Hardened Steel:** for high tensile, torque and shear strength.
- For interior/exterior use in; wood, plastic, cement fibre board, particle board, sheet metal, wood decking and melamine.

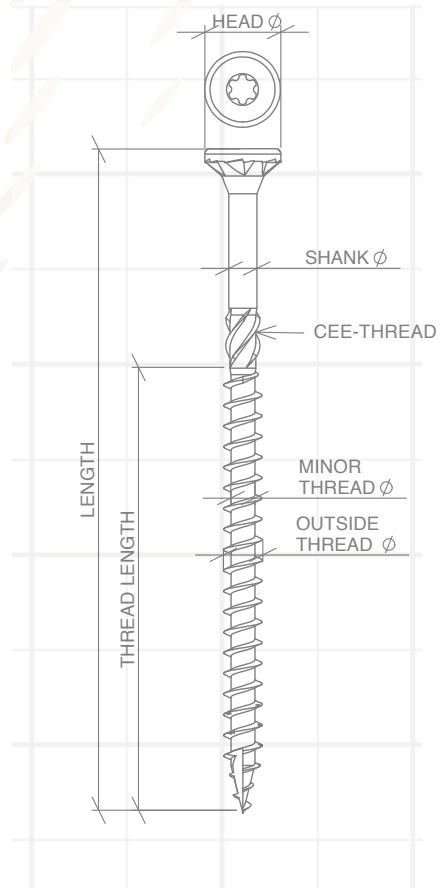

## Deck Elite™ Decking Screws

### APPLICATIONS



### SELECTION CHART



T-15



T-25

U.S. (STD.) SIZE (DIA. X LENGTH)	METRIC SIZE (DIA. X LENGTH)	PAIL PART NO.	PAIL QTY.	PRO-PAK PART NO.	PRO-PAK PAIL QTY.
#8 X 1-1/2	4.0 x 40	20073	2700	21073	850
#8 X 2-1/2	4.0 x 63	20079	1600	21079	600
#8 X 3	4.0 X 76	20080	1300	21080	450
#10 X 2-1/2	4.5 X 63	20133	1000	21133	400
#10 X 3	4.5 X 76	20136	1000	21136	350
#10 X 3-1/2	4.5 X 90	20139	1000	21139	300

Driver bit included in Pro-Paks and Pail.

**NOTE:** Pro-Paks need to be ordered in multiples of two.

### Frame with Ease and Confidence



### DESCRIPTION/SUGGESTED SPECIFICATIONS

#### Multi-Purpose Framing Screws—

GRK's R4<sup>™</sup> self-countersinking screw has a patented underhead with saw-blade like cutting teeth and six self-contained cutting pockets. Together they act similar to a circular saw-blade, transporting the drill dust away from the edge of the screw hole while cutting a perfectly clean hole into even the most brittle materials without cracking any surface treatment.

#### ÜberGrade<sup>™</sup>



This design enhances the R4<sup>™</sup>'s versatility by allowing the fastener to countersink into even the hardest woods. The head of the screw closes the hole off with precision, leaving no damaged fibres around the head.

R4<sup>™</sup> screws 2" and longer have a four threaded CEE Thread. This enlarges the screw hole for the non-threaded portion of the fastener, allowing the wood to settle easily. It increases the screw's drawing strength and reduces the friction on the screw shank that lowers the driving torque.

### ADVANTAGES

- **Recessed Star Drive:** Zero Stripping, with 6 points of contact.
- **CEE Thread:** Enlarges hole to reduce splitting, install torque.
- **W-Cut<sup>™</sup>:** Low torque, smoother drive, reduce splitting.
- **Zip-Tip<sup>™</sup>:** No pre-drilling, faster penetration, reduce splitting.
- **Cutting Pockets:** provide a clean hole, reduces splitting, and bore with precision.
- **ESR-3201 Approved** for structural application.
- **Case Hardened Steel:** for high tensile, torque and shear strength.
- **Climatek<sup>™</sup> Coating** is AC257 code approved for use in treated lumber.
- For interior/exterior use in; wood, plastic, cement fibre board, particle board, sheet metal, wood decking and melamine.

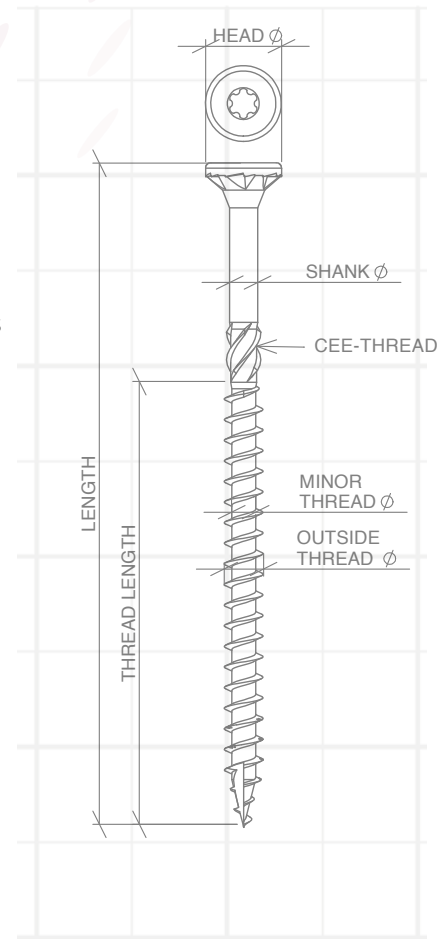

### APPROVALS/LISTING





## R4™ Multi-Purpose Framing Screws

### APPLICATIONS



### SELECTION CHART



T-15



T-25



T-25



T-25

	U.S. (STD.) SIZE (DIA. X LENGTH)	METRIC SIZE (DIA. X LENGTH)	BULK PART NO.	BULK BOX QTY.	PRO-PAK PART NO.	PRO-PAK PAIL QTY.	HANDY-PAK PART NO.	HANDY-PAK CTN. SIZE/QTY.
T-15	#8 x 1-1/2"	4.0 x 40			01073	1,000		
	#8 x 2"	4.0 x 50			01077	850	02077	S/100
T-25	#9 x 1-3/4"	4.5 x 45					02097	S/100
	#9 x 2"	4.5 x 50	00099	3,700	01099	690		
	#9 x 2-1/2"	4.5 x 63	00101	2,900	01101	575	02101	M/100
	#9 x 2-3/4"	4.5 x 70			01103	480		M/100
T-25	#9 x 3-1/8"	4.5 x 80	00105	1,900	01105	425	02105	M/100
	#10 x 2-1/2"	5.0 x 63	00133	2,500	01133	470		
	#10 x 2-3/4"	5.0 x 70	00135	2,000				
	#10 x 3-1/8"	5.0 x 80	00137	1,500	01137	350	02137	M/100
	#10 x 3-1/2"	5.0 x 90	00139	1,200	01139	300	02139	M/50
	#10 x 4"	5.0 x 100	00141	1,000	01141	270	02141	M/50
	#10 x 4-3/4"	5.0 x 120	00143	800	01143	230	02143	M/50
	T-25	#12/14 x 4"	6.0 x 100	00165	800			
#12/14 x 5-5/8"		6.0 x 140	00173	600			02173	M/50
#12/14 x 6-3/8"		6.0 x 160	00177	1,000			02177	M/9
#12/14 x 7-1/4"		6.0 x 180	00179	1,000			02179	M/9
#12/14 x 8"		6.0 x 200	00181	500			02181	M/9
#12/14 x 10"		6.0 x 250					02187	M/12
	#12/14 x 12"	6.0 x 300					02193	M/12

2" bit included in Pro-Paks, 1" bits in Handy-Paks.

\*Does not come with the Zip-Tip™ feature. **NOTE:** Pro-Paks need to be ordered in multiples of two.

## GRK R4 Spacings

MINIMUM ROW SPACING, SPACING IN ROW AND EDGE DISTANCES AS SPECIFIED IN CLAUSE 12.11 CSA 086-14

R4 NOMINAL DIA.	OUTSIDE THREAD DIA. (IN.)	DIMENSION (SEE FIGURE)	POINT SIDE MEMBER SPECIES	
			D. FIR-L	S-P-F
			MINIMUM DIMENSIONS (in)	
9 x L	0.173	a - Spacing parallel to grain	3.5	2.8
		b - End distance parallel to grain	2.6	2.1
		c - Spacing perpendicular to grain	1.7	1.4
		d - Edge distance perpendicular to grain	0.9	0.7
10 x L	0.193	a - Spacing parallel to grain	3.9	3.1
		b - End distance parallel to grain	2.9	2.3
		c - Spacing perpendicular to grain	1.9	1.5
		d - Edge distance perpendicular to grain	1.0	0.8
12 x L	0.234	a - Spacing parallel to grain	4.7	3.7
		b - End distance parallel to grain	3.5	2.8
		c - Spacing perpendicular to grain	2.3	1.9
		d - Edge distance perpendicular to grain	1.2	0.9

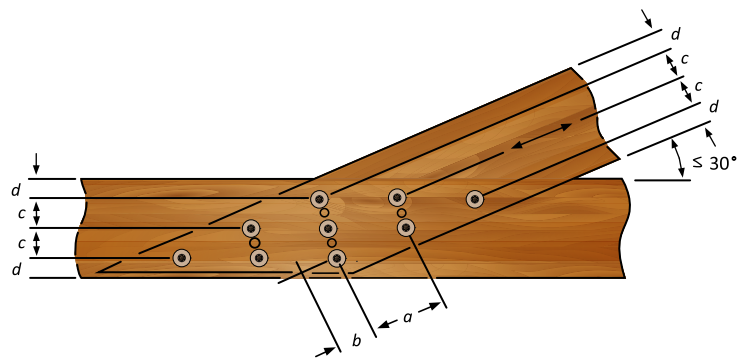
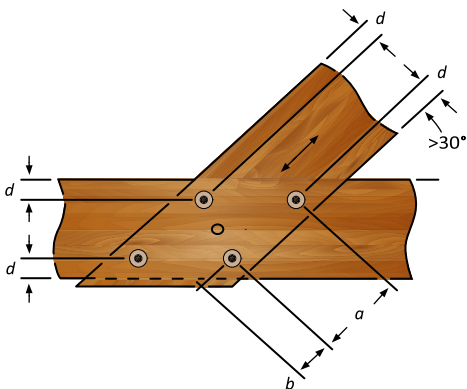
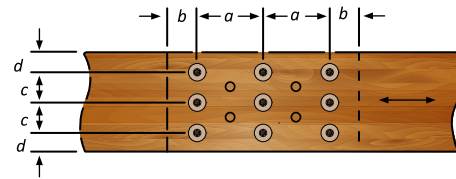
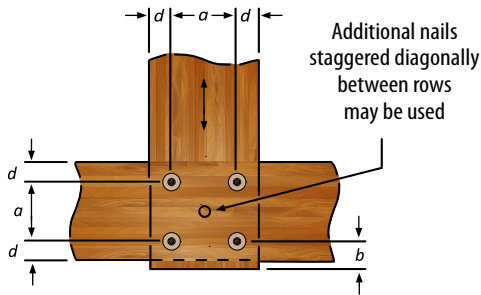

## R4™ Multi-Purpose Framing Screws

### GRK R4 9 x L SAWN LUMBER SIDE PL

MODEL/BULK PART NO.	R4 NOMINAL DIA.	SHANK DIAMETER (in.)	SCREW LENGTH (in.)	HEAD DIAMETER (in.)	OUTSIDE THREAD DIAMETER (in.)	THREAD LENGTH (in.)	POINT-SIDE MEMBER: D.FIR-L SAWN LUMBER			
							SIDE MEMBER: D.FIR-L SAWN LUMBER THICKNESS OF SIDE MEMBER (in.)			
							1.5	2	1.5	2
							LATERAL RESISTANCE		WITHDRAWAL RESISTANCE	
LB.	LB.	LB.	LB.							
kN	kN	kN	kN							
00099	9 x 2"	0.128	2	0.329	0.173	1.25	---	---	---	
00101	9 x 2-1/2"		2.375			1.625	155	---	168	---
01103	9 x 2-3/4"		2.75			1.875	181	146	223	144
							0.81	0.65	0.99	0.64
00105	9 x 3-1/8"		3.125			1.625	186	172	223	217
							0.83	0.77	0.99	0.96
00105	9 x 3-1/8"		3.125			2.125	186	172	223	217
							0.83	0.77	0.99	0.96

MODEL/BULK PART NO.	R4 NOMINAL DIA.	SHANK DIAMETER (in.)	SCREW LENGTH (in.)	HEAD DIAMETER (in.)	OUTSIDE THREAD DIAMETER (in.)	THREAD LENGTH (in.)	POINT-SIDE MEMBER: D.FIR-L SAWN LUMBER			
							SIDE MEMBER: S-P-F SAWN LUMBER THICKNESS OF SIDE MEMBER (in.)			
							1.5	2	1.5	2
							LATERAL RESISTANCE		WITHDRAWAL RESISTANCE	
LB.	LB.	LB.	LB.							
kN	kN	kN	kN							
00099	9 x 2"	0.128	2	0.329	0.173	1.25	---	---	---	
00101	9 x 2-1/2"		2.375			1.625	137	---	128	---
01103	9 x 2-3/4"		2.75			1.875	159	129	183	110
							0.71	0.57	0.81	0.49
00105	9 x 3-1/8"		3.125			1.625	168	152	223	165
							0.75	0.67	0.99	0.73
00105	9 x 3-1/8"		3.125			2.125	168	152	223	165
							0.75	0.67	0.99	0.73

<sup>1</sup> Resistance values have been developed in accordance with Clause 12.11 "Wood Screws" CSA 086-14 and have been factored with the material resistance factor ( $\phi$ ). No other modification factors affecting resistance have been applied. Values must be multiplied by all applicable modification factors as specified for wood screws in accordance with CSA 086-14.

<sup>2</sup> ICC ESR-3201 report can be referred to for information not provided in this table. Note that resistance values of GRK R4 screw connections with cold-formed steel, mild steel and plywood side members have not been developed in the ICC ESR-3201 report.

<sup>3</sup> Multiply lateral resistance values by 0.83 for toe-screw installation and by 0.67 for end-grain installation. Toe-screw and end-grain installations are not permitted for screws loaded in withdrawal.

<sup>4</sup> Minimum row spacing, spacing in row and edge distances, penetration lengths, and member thicknesses shall be as specified in Clause 12.11.2 CSA 086-14. The minimum spacing table provided in this catalogue can be used for reference.

<sup>5</sup> '---' indicates the screw cannot be used for the resistance due to the screw length not meeting the minimum penetration length into the point-side member. Resistance values have been developed assuming the screw is fully penetrated into the point-side member.

<sup>6</sup> Resistance values with mild steel side member have been developed for mild steel referenced in CSA S16 (ASTM A36/A36M steel;  $f_u = 400$  MPa). Resistance values with cold-formed steel side member have been developed for cold-formed steel light gauge steel referenced in CSA S136 (Grade SS 230;  $f_u = 310$  MPa).

<sup>7</sup> Convert inches to millimetres by multiplying the value by 25.4 (1 in. = 25.4 mm).

# R4™ Multi-Purpose Framing Screws

## GRK R4 9 x L PLYWOOD SIDE PL

MODEL/ BULK PART NO.	R4 NOMINAL DIA.	SHANK DIAMETER (in.)	SCREW LENGTH (in.)	HEAD DIAMETER (in.)	OUTSIDE THREAD DIAMETER (in.)	THREAD LENGTH (in.)	POINT-SIDE MEMBER: D.FIR-L SAWN LUMBER							
							SIDE MEMBER: DFP PANEL THICKNESS OF SIDE MEMBER (in.)							
							3/8	1/2	5/8	3/4	3/8	1/2	5/8	3/4
							LATERAL RESISTANCE				WITHDRAWAL RESISTANCE			
							LB.	LB.	LB.	LB.	LB.	LB.	LB.	LB.
kN	kN	kN	kN	kN	kN	kN	kN							
00099	9 x 2"	0.128	2	0.329	0.173	1.25	141	153	161	165	56	74	93	111
							0.63	0.68	0.71	0.73	0.25	0.33	0.41	0.50
00101	9 x 2-1/2"		2.375			1.625	141	153	166	179	56	74	93	111
							0.63	0.68	0.74	0.80	0.25	0.33	0.41	0.50
01103	9 x 2-3/4"		2.75			1.875	141	153	166	179	56	74	93	111
							0.63	0.68	0.74	0.80	0.25	0.33	0.41	0.50
00105	9 x 3-1/8"		3.125			1.625	141	153	166	179	56	74	93	111
							0.63	0.68	0.74	0.80	0.25	0.33	0.41	0.50
00105	9 x 3-1/8"		3.125			2.125	141	153	166	179	56	74	93	111
							0.63	0.68	0.74	0.80	0.25	0.33	0.41	0.50

MODEL/ BULK PART NO.	R4 NOMINAL DIA.	SHANK DIAMETER (in.)	SCREW LENGTH (in.)	HEAD DIAMETER (in.)	OUTSIDE THREAD DIAMETER (in.)	THREAD LENGTH (in.)	POINT-SIDE MEMBER: S-P-F SAWN LUMBER							
							SIDE MEMBER: CSP PLYWOOD THICKNESS OF SIDE MEMBER (IN.)							
							3/8	1/2	5/8	3/4	3/8	1/2	5/8	3/4
							LATERAL RESISTANCE				WITHDRAWAL RESISTANCE			
							LB.	LB.	LB.	LB.	LB.	LB.	LB.	LB.
kN	kN	kN	kN	kN	kN	kN	kN							
00099	9 x 2"	0.128	2	0.329	0.173	1.25	124	134	138	141	56	74	93	111
							0.55	0.60	0.61	0.63	0.25	0.33	0.41	0.50
00101	9 x 2-1/2"		2.375			1.625	124	135	146	157	56	74	93	111
							0.55	0.60	0.65	0.70	0.25	0.33	0.41	0.50
01103	9 x 2-3/4"		2.75			1.875	124	135	146	157	56	74	93	111
							0.55	0.60	0.65	0.70	0.25	0.33	0.41	0.50
00105	9 x 3-1/8"		3.125			1.625	124	135	146	157	56	74	93	111
							0.55	0.60	0.65	0.70	0.25	0.33	0.41	0.50
00105	9 x 3-1/8"		3.125			2.125	124	135	146	157	56	74	93	111
							0.55	0.60	0.65	0.70	0.25	0.33	0.41	0.50

<sup>1</sup> Resistance values have been developed in accordance with Clause 12.11 "Wood Screws" CSA 086-14 and have been factored with the material resistance factor ( $\phi$ ). No other modification factors affecting resistance have been applied. Values must be multiplied by all applicable modification factors as specified for wood screws in accordance with CSA 086-14.

<sup>2</sup> ICC ESR-3201 report can be referred to for information not provided in this table. Note that resistance values of GRK R4 screw connections with cold-formed steel, mild steel and plywood side members have not been developed in the ICC ESR-3201 report.

<sup>3</sup> Multiply lateral resistance values by 0.83 for toe-screw installation and by 0.67 for end-grain installation. Toe-screw and end-grain installations are not permitted for screws loaded in withdrawal.

<sup>4</sup> Minimum row spacing, spacing in row and edge distances, penetration lengths, and member thicknesses shall be as specified in Clause 12.11.2 CSA 086-14. The minimum spacing table provided in this catalogue can be used for reference.

<sup>5</sup> '---' indicates the screw cannot be used for the resistance due to the screw length not meeting the minimum penetration length into the point-side member. Resistance values have been developed assuming the screw is fully penetrated into the point-side member.

<sup>6</sup> Resistance values with mild steel side member have been developed for mild steel referenced in CSA S16 (ASTM A36/A36M steel;  $f_u = 400$  MPa). Resistance values with cold-formed steel side member have been developed for cold-formed steel light gauge steel referenced in CSA S136 (Grade SS 230;  $f_u = 310$  MPa).

<sup>7</sup> Convert inches to millimetres by multiplying the value by 25.4 (1 in. = 25.4 mm).

## GRK R4 9 x L COLD-FORMED STEEL SIDE PL

MODEL/ BULK PART NO.	R4 NOMINAL DIA.	SHANK DIAMETER (in.)	SCREW LENGTH (in.)	HEAD DIAMETER (in.)	OUTSIDE THREAD DIAMETER (in.)	THREAD LENGTH (in.)	POINT-SIDE MEMBER: D.FIR-L SAWN LUMBER									
							SIDE MEMBER: COLD-FORMED STEEL THICKNESS OF SIDE MEMBER (in.)									
							20 GA.	18 GA.	16 GA.	14 GA.	12 GA.	20 GA.	18 GA.	16 GA.	14 GA.	12 GA.
							LATERAL RESISTANCE					WITHDRAWAL RESISTANCE				
							LB.	LB.	LB.	LB.	LB.	LB.	LB.	LB.	LB.	LB.
00099	9 x 2"	0.128	2	0.329	0.173	1.25	180	194	209	228	264	241	241	241	241	241
			0.80				0.86	0.93	1.01	1.17	1.07	1.07	1.07	1.07	1.07	
00101	9 x 2-1/2"		2.375			1.625	180	194	209	228	265	313	313	313	313	313
			0.80				0.86	0.93	1.01	1.18	1.39	1.39	1.39	1.39	1.39	
01103	9 x 2-3/4"		2.75			1.875	180	194	209	228	265	320	361	361	361	361
			0.80				0.86	0.93	1.01	1.18	1.42	1.61	1.61	1.61	1.61	
00105	9 x 3-1/8"		3.125			1.625	180	194	209	228	265	313	313	313	313	313
			0.80				0.86	0.93	1.01	1.18	1.39	1.39	1.39	1.39	1.39	
00105	9 x 3-1/8"		3.125			2.125	180	194	209	228	265	320	409	409	409	409
			0.80				0.86	0.93	1.01	1.18	1.42	1.82	1.82	1.82	1.82	

MODEL/ BULK PART NO.	R4 NOMINAL DIA.	SHANK DIAMETER (in.)	SCREW LENGTH (in.)	HEAD DIAMETER (in.)	OUTSIDE THREAD DIAMETER (in.)	THREAD LENGTH (in.)	POINT-SIDE MEMBER: S-P-F SAWN LUMBER									
							SIDE MEMBER: COLD-FORMED STEEL THICKNESS OF SIDE MEMBER (in.)									
							20 GA.	18 GA.	16 GA.	14 GA.	12 GA.	20 GA.	18 GA.	16 GA.	14 GA.	12 GA.
							LATERAL RESISTANCE					WITHDRAWAL RESISTANCE				
							LB.	LB.	LB.	LB.	LB.	LB.	LB.	LB.	LB.	LB.
00099	9 x 2"	0.128	2	0.329	0.173	1.25	163	177	192	209	236	183	183	183	183	183
			0.73				0.79	0.85	0.93	1.05	0.81	0.81	0.81	0.81	0.81	
00101	9 x 2-1/2"		2.375			1.625	163	178	193	211	236	238	238	238	238	238
			0.73				0.79	0.86	0.94	1.05	1.06	1.06	1.06	1.06	1.06	
01103	9 x 2-3/4"		2.75			1.875	163	178	193	211	236	275	275	275	275	275
			0.73				0.79	0.86	0.94	1.05	1.22	1.22	1.22	1.22	1.22	
00105	9 x 3-1/8"		3.125			1.625	163	178	193	211	236	238	238	238	238	238
			0.73				0.79	0.86	0.94	1.05	1.06	1.06	1.06	1.06	1.06	
00105	9 x 3-1/8"		3.125			2.125	163	178	193	211	236	311	311	311	311	311
			0.73				0.79	0.86	0.94	1.05	1.39	1.39	1.39	1.39	1.39	

<sup>1</sup> Resistance values have been developed in accordance with Clause 12.11 "Wood Screws" CSA 086-14 and have been factored with the material resistance factor ( $\phi$ ). No other modification factors affecting resistance have been applied. Values must be multiplied by all applicable modification factors as specified for wood screws in accordance with CSA 086-14.

<sup>2</sup> ICC ESR-3201 report can be referred to for information not provided in this table. Note that resistance values of GRK R4 screw connections with cold-formed steel, mild steel and plywood side members have not been developed in the ICC ESR-3201 report.

<sup>3</sup> Multiply lateral resistance values by 0.83 for toe-screw installation and by 0.67 for end-grain installation. Toe-screw and end-grain installations are not permitted for screws loaded in withdrawal.

<sup>4</sup> Minimum row spacing, spacing in row and edge distances, penetration lengths, and member thicknesses shall be as specified in Clause 12.11.2 CSA 086-14. The minimum spacing table provided in this catalogue can be used for reference.

<sup>5</sup> '---' indicates the screw cannot be used for the resistance due to the screw length not meeting the minimum penetration length into the point-side member. Resistance values have been developed assuming the screw is fully penetrated into the point-side member.

<sup>6</sup> Resistance values with mild steel side member have been developed for mild steel referenced in CSA S16 (ASTM A36/A36M steel;  $f_u = 400$  MPa). Resistance values with cold-formed steel side member have been developed for cold-formed steel light gauge steel referenced in CSA S136 (Grade SS 230;  $f_u = 310$  MPa).

<sup>7</sup> Convert inches to millimetres by multiplying the value by 25.4 (1 in. = 25.4 mm).

# R4™ Multi-Purpose Framing Screws

## GRK R4 9xL MILD STEEL SIDE PL

MODEL/ BULK PART NO.	R4 NOMINAL DIA.	SHANK DIAMETER (in.)	SCREW LENGTH (in.)	HEAD DIAMETER (in.)	OUTSIDE THREAD DIAMETER (in.)	THREAD LENGTH (in.)	POINT-SIDE MEMBER: D.FIR-L SAWN LUMBER									
							SIDE MEMBER: MILD STEEL THICKNESS OF SIDE MEMBER (in.)									
							1/8	9/64	3/16	1/4	1/2	1/8	9/64	3/16	1/4	1/2
							LATERAL RESISTANCE					WITHDRAWAL RESISTANCE				
							LB.	LB.	LB.	LB.	LB.	LB.	LB.	LB.	LB.	LB.
kN	kN	kN	kN	kN	kN	kN	kN	kN	kN							
00099	9 x 2"	0.128	2	0.173	0.329	1.25	275	275	275	275	275	241	241	241	241	241
							1.23	1.23	1.23	1.23	1.23	1.07	1.07	1.07	1.07	1.07
00101	9 x 2-1/2"		2.375			1.625	275	275	275	275	275	313	313	313	313	313
							1.23	1.23	1.23	1.23	1.23	1.39	1.39	1.39	1.39	1.39
01103	9 x 2-3/4"		2.75			1.875	275	275	275	275	275	361	361	361	361	361
							1.23	1.23	1.23	1.23	1.23	1.61	1.61	1.61	1.61	1.61
00105	9 x 3-1/8"		3.125			1.625	275	275	275	275	275	313	313	313	313	313
							1.23	1.23	1.23	1.23	1.23	1.39	1.39	1.39	1.39	1.39
00105	9 x 3-1/8"		3.125			2.125	275	275	275	275	275	409	409	409	409	409
							1.23	1.23	1.23	1.23	1.23	1.82	1.82	1.82	1.82	1.82

MODEL/ BULK PART NO.	R4 NOMINAL DIA.	SHANK DIAMETER (in.)	SCREW LENGTH (in.)	HEAD DIAMETER (in.)	OUTSIDE THREAD DIAMETER (in.)	THREAD LENGTH (in.)	POINT-SIDE MEMBER: S-P-F SAWN LUMBER									
							SIDE MEMBER: MILD STEEL THICKNESS OF SIDE MEMBER (in.)									
							1/8	9/64	3/16	1/4	1/2	1/8	9/64	3/16	1/4	1/2
							LATERAL RESISTANCE					WITHDRAWAL RESISTANCE				
							LB.	LB.	LB.	LB.	LB.	LB.	LB.	LB.	LB.	LB.
kN	kN	kN	kN	kN	kN	kN	kN	kN	kN							
00099	9 x 2"	0.128	2	0.173	0.329	1.25	240	240	240	240	240	183	183	183	183	183
							1.07	1.07	1.07	1.07	1.07	0.81	0.81	0.81	0.81	0.81
00101	9 x 2-1/2"		2.375			1.625	240	240	240	240	240	238	238	238	238	238
							1.07	1.07	1.07	1.07	1.07	1.06	1.06	1.06	1.06	1.06
01103	9 x 2-3/4"		2.75			1.875	240	240	240	240	240	275	275	275	275	275
							1.07	1.07	1.07	1.07	1.07	1.22	1.22	1.22	1.22	1.22
00105	9 x 3-1/8"		3.125			1.625	240	240	240	240	240	238	238	238	238	238
							1.07	1.07	1.07	1.07	1.07	1.06	1.06	1.06	1.06	1.06
00105	9 x 3-1/8"		3.125			2.125	240	240	240	240	240	311	311	311	311	311
							1.07	1.07	1.07	1.07	1.07	1.39	1.39	1.39	1.39	1.39

<sup>1</sup> Resistance values have been developed in accordance with Clause 12.11 "Wood Screws" CSA 086-14 and have been factored with the material resistance factor ( $\phi$ ). No other modification factors affecting resistance have been applied. Values must be multiplied by all applicable modification factors as specified for wood screws in accordance with CSA 086-14.

<sup>2</sup> ICC ESR-3201 report can be referred to for information not provided in this table. Note that resistance values of GRK R4 screw connections with cold-formed steel, mild steel and plywood side members have not been developed in the ICC ESR-3201 report.

<sup>3</sup> Multiply lateral resistance values by 0.83 for toe-screw installation and by 0.67 for end-grain installation. Toe-screw and end-grain installations are not permitted for screws loaded in withdrawal.

<sup>4</sup> Minimum row spacing, spacing in row and edge distances, penetration lengths, and member thicknesses shall be as specified in Clause 12.11.2 CSA 086-14. The minimum spacing table provided in this catalogue can be used for reference.

<sup>5</sup> '---' indicates the screw cannot be used for the resistance due to the screw length not meeting the minimum penetration length into the point-side member. Resistance values have been developed assuming the screw is fully penetrated into the point-side member.

<sup>6</sup> Resistance values with mild steel side member have been developed for mild steel referenced in CSA S16 (ASTM A36/A36M steel;  $f_u = 400$  MPa). Resistance values with cold-formed steel side member have been developed for cold-formed steel light gauge steel referenced in CSA S136 (Grade SS 230;  $f_u = 310$  MPa).

<sup>7</sup> Convert inches to millimetres by multiplying the value by 25.4 (1 in. = 25.4 mm).

## GRK R4 10xL SAWN LUMBER SIDE PL

MODEL/ BULK PART NO.	R4 NOMINAL DIA.	SHANK DIAMETER (in.)	SCREW LENGTH (in.)	HEAD DIAMETER (in.)	OUTSIDE THREAD DIAMETER (in.)	THREAD LENGTH (in.)	POINT-SIDE MEMBER: D.FIR-L SAWN LUMBER									
							SIDE MEMBER: D.FIR-L SAWN LUMBER THICKNESS OF SIDE MEMBER (in.)									
							1.5	2	2.5	3	3.5	1.5	2	2.5	3	3.5
							LATERAL RESISTANCE					WITHDRAWAL RESISTANCE				
LB.	LB.	LB.	LB.	LB.	LB.	LB.	LB.	LB.	LB.	LB.						
kN	kN	kN	kN	kN	kN	kN	kN	kN	kN	kN						
00133	10 x 2-1/2"	0.142	2.375	0.368	0.193	1.625	177	---	---	---	---	184	---	---	---	---
							0.79	---	---	---	---	0.82	---	---	---	---
00135	10 x 2-3/4"		2.75			1.875	206	167	---	---	---	223	158	---	---	---
							0.92	0.74	---	---	---	0.99	0.70	---	---	---
00137	10 x 3-1/8"		3.125			1.625	217	196	---	---	---	223	237	---	---	---
							0.97	0.87	---	---	---	0.99	1.05	---	---	---
00139	10 x 3-1/2"		3.5			2	217	217	187	---	---	223	297	211	---	---
							0.97	0.97	0.83	---	---	0.99	1.32	0.94	---	---
00141	10 x 4"	3.875	2.625	217	217	216	177	---	223	297	290	184	---			
				0.97	0.97	0.96	0.79	---	0.99	1.32	1.29	0.82	---			
00143	10 x 4-3/4"	4.625	3	217	217	217	217	196	223	297	371	342	237			
				0.97	0.97	0.97	0.97	0.87	0.99	1.32	1.65	1.52	1.05			

MODEL/ BULK PART NO.	R4 NOMINAL DIA.	SHANK DIAMETER (in.)	SCREW LENGTH (in.)	HEAD DIAMETER (in.)	OUTSIDE THREAD DIAMETER (in.)	THREAD LENGTH (in.)	POINT-SIDE MEMBER: S-P-F SAWN LUMBER									
							SIDE MEMBER: S-P-F SAWN LUMBER THICKNESS OF SIDE MEMBER (in.)									
							1.5	2	2.5	3	3.5	1.5	2	2.5	3	3.5
							LATERAL RESISTANCE					WITHDRAWAL RESISTANCE				
LB.	LB.	LB.	LB.	LB.	LB.	LB.	LB.	LB.	LB.	LB.						
kN	kN	kN	kN	kN	kN	kN	kN	kN	kN	kN						
00133	10 x 2-1/2"	0.142	2.375	0.368	0.193	1.625	156	---	---	---	---	140	---	---	---	---
							0.69	---	---	---	---	0.62	---	---	---	---
00135	10 x 2-3/4"		2.75			1.875	181	148	---	---	---	200	120	---	---	---
							0.81	0.66	---	---	---	0.89	0.53	---	---	---
00137	10 x 3-1/8"		3.125			1.625	196	173	---	---	---	223	180	---	---	---
							0.87	0.77	---	---	---	0.99	0.80	---	---	---
00139	10 x 3-1/2"		3.5			2	196	196	165	---	---	223	240	160	---	---
							0.87	0.87	0.73	---	---	0.99	1.07	0.71	---	---
00141	10 x 4"	3.875	2.625	196	196	156	156	---	223	297	220	140	---			
				0.87	0.87	0.69	0.69	---	0.99	1.32	0.98	0.62	---			
00143	10 x 4-3/4"	4.625	3	196	196	196	196	173	223	297	371	260	180			
				0.87	0.87	0.87	0.87	0.77	0.99	1.32	1.65	1.16	0.80			

- Resistance values have been developed in accordance with Clause 12.11 "Wood Screws" CSA 086-14 and have been factored with the material resistance factor ( $\phi$ ). No other modification factors affecting resistance have been applied. Values must be multiplied by all applicable modification factors as specified for wood screws in accordance with CSA 086-14.
- ICC ESR-3201 report can be referred to for information not provided in this table. Note that resistance values of GRK R4 screw connections with cold-formed steel, mild steel and plywood side members have not been developed in the ICC ESR-3201 report.
- Multiply lateral resistance values by 0.83 for toe-screw installation and by 0.67 for end-grain installation. Toe-screw and end-grain installations are not permitted for screws loaded in withdrawal.
- Minimum row spacing, spacing in row and edge distances, penetration lengths, and member thicknesses shall be as specified in Clause 12.11.2 CSA 086-14. The minimum spacing table provided in this catalogue can be used for reference.
- '---' indicates the screw cannot be used for the resistance due to the screw length not meeting the minimum penetration length into the point-side member. Resistance values have been developed assuming the screw is fully penetrated into the point-side member.
- Resistance values with mild steel side member have been developed for mild steel referenced in CSA S16 (ASTM A36/A36M steel;  $f_u = 400$  MPa). Resistance values with cold-formed steel side member have been developed for cold-formed steel light gauge steel referenced in CSA S136 (Grade SS 230;  $f_u = 310$  MPa).
- Convert inches to millimetres by multiplying the value by 25.4 (1 in. = 25.4 mm).

# R4™ Multi-Purpose Framing Screws

## GRK R4 10xL PLYWOOD SIDE PL

MODEL/ BULK PART NO.	R4 NOMINAL DIA.	SHANK DIAMETER (in.)	SCREW LENGTH (in.)	HEAD DIAMETER (in.)	OUTSIDE THREAD DIAMETER (in.)	THREAD LENGTH (in.)	POINT-SIDE MEMBER: D.FIR-L SAWN LUMBER							
							SIDE MEMBER: DFP PANEL THICKNESS OF SIDE MEMBER (in.)							
							3/8	1/2	5/8	3/4	3/8	1/2	5/8	3/4
							LATERAL RESISTANCE				WITHDRAWAL RESISTANCE			
							LB.	LB.	LB.	LB.	LB.	LB.	LB.	LB.
kN	kN	kN	kN	kN	kN	kN	kN							
00133	10 x 2-1/2"	0.142	2.375	0.368	0.193	1.625	158	172	185	199	56	74	93	111
			0.70				0.76	0.82	0.88	0.25	0.33	0.41	0.50	
00135	10 x 2-3/4"		2.75			1.875	158	172	185	199	56	74	93	111
			0.70				0.76	0.82	0.88	0.25	0.33	0.41	0.50	
00137	10 x 3-1/8"		3.125			1.625	158	172	185	199	56	74	93	111
			0.70				0.76	0.82	0.88	0.25	0.33	0.41	0.50	
00139	10 x 3-1/2"		3.5			2	158	172	185	199	56	74	93	111
			0.70				0.76	0.82	0.88	0.25	0.33	0.41	0.50	
00141	10 x 4"	3.875	2.625	158	172	185	199	56	74	93	111			
		0.70		0.76	0.82	0.88	0.25	0.33	0.41	0.50				
00143	10 x 4-3/4"	4.625	3	158	172	185	199	56	74	93	111			
		0.70		0.76	0.82	0.88	0.25	0.33	0.41	0.50				

MODEL/ BULK PART NO.	R4 NOMINAL DIA.	SHANK DIAMETER (in.)	SCREW LENGTH (in.)	HEAD DIAMETER (in.)	OUTSIDE THREAD DIAMETER (in.)	THREAD LENGTH (in.)	POINT-SIDE MEMBER: S-P-F SAWN LUMBER							
							SIDE MEMBER: CSP PLYWOOD THICKNESS OF SIDE MEMBER (IN.)							
							3/8	1/2	5/8	3/4	3/8	1/2	5/8	3/4
							LATERAL RESISTANCE				WITHDRAWAL RESISTANCE			
							LB.	LB.	LB.	LB.	LB.	LB.	LB.	LB.
kN	kN	kN	kN	kN	kN	kN	kN							
00133	10 x 2-1/2"	0.142	2.375	0.368	0.193	1.625	140	152	163	175	56	74	93	111
			0.62				0.68	0.73	0.78	0.25	0.33	0.41	0.50	
00135	10 x 2-3/4"		2.75			1.875	140	152	163	175	56	74	93	111
			0.62				0.68	0.73	0.78	0.25	0.33	0.41	0.50	
00137	10 x 3-1/8"		3.125			1.625	140	152	163	175	56	74	93	111
			0.62				0.68	0.73	0.78	0.25	0.33	0.41	0.50	
00139	10 x 3-1/2"		3.5			2	140	152	163	175	56	74	93	111
			0.62				0.68	0.73	0.78	0.25	0.33	0.41	0.50	
00141	10 x 4"	3.875	2.625	140	152	163	175	56	74	93	111			
		0.62		0.68	0.73	0.78	0.25	0.33	0.41	0.50				
00143	10 x 4-3/4"	4.625	3	140	152	163	175	56	74	93	111			
		0.62		0.68	0.73	0.78	0.25	0.33	0.41	0.50				

<sup>1</sup> Resistance values have been developed in accordance with Clause 12.11 "Wood Screws" CSA O86-14 and have been factored with the material resistance factor ( $\phi$ ). No other modification factors affecting resistance have been applied. Values must be multiplied by all applicable modification factors as specified for wood screws in accordance with CSA O86-14.

<sup>2</sup> ICC ESR-3201 report can be referred to for information not provided in this table. Note that resistance values of GRK R4 screw connections with cold-formed steel, mild steel and plywood side members have not been developed in the ICC ESR-3201 report.

<sup>3</sup> Multiply lateral resistance values by 0.83 for toe-screw installation and by 0.67 for end-grain installation. Toe-screw and end-grain installations are not permitted for screws loaded in withdrawal.

<sup>4</sup> Minimum row spacing, spacing in row and edge distances, penetration lengths, and member thicknesses shall be as specified in Clause 12.11.2 CSA O86-14. The minimum spacing table provided in this catalogue can be used for reference.

<sup>5</sup> '---' indicates the screw cannot be used for the resistance due to the screw length not meeting the minimum penetration length into the point-side member. Resistance values have been developed assuming the screw is fully penetrated into the point-side member.

<sup>6</sup> Resistance values with mild steel side member have been developed for mild steel referenced in CSA S16 (ASTM A36/A36M steel;  $f_u = 400$  MPa). Resistance values with cold-formed steel side member have been developed for cold-formed steel light gauge steel referenced in CSA S136 (Grade SS 230;  $f_u = 310$  MPa).

<sup>7</sup> Convert inches to millimetres by multiplying the value by 25.4 (1 in. = 25.4 mm).



## GRK R4 10xL COLD-FORMED STEEL SIDE PL

MODEL/ BULK PART NO.	R4 NOMINAL DIA.	SHANK DIAMETER (in.)	SCREW LENGTH (in.)	HEAD DIAMETER (in.)	OUTSIDE THREAD DIAMETER (in.)	THREAD LENGTH (in.)	POINT-SIDE MEMBER SPECIES: D.FIR-L SAWN LUMBER									
							SIDE MEMBER: COLD-FORMED STEEL THICKNESS OF SIDE MEMBER (in.)									
							20 GA.	18 GA.	16 GA.	14 GA.	12 GA.	20 GA.	18 GA.	16 GA.	14 GA.	12 GA.
							LATERAL RESISTANCE					WITHDRAWAL RESISTANCE				
							LB.	LB.	LB.	LB.	LB.	LB.	LB.	LB.	LB.	LB.
kN	kN	kN	kN	kN	kN	kN	kN	kN	kN							
00133	10 x 2-1/2"	0.142	2.375	0.368	0.193	1.625	207	224	240	261	302	342	342	342	342	342
			0.92				0.99	1.07	1.16	1.34	1.52	1.52	1.52	1.52	1.52	
00135	10 x 2-3/4"		2.75			1.875	207	224	240	261	302	357	395	395	395	395
			0.92				0.99	1.07	1.16	1.34	1.59	1.76	1.76	1.76	1.76	
00137	10 x 3-1/8"		3.125			1.625	207	224	240	261	302	342	342	342	342	342
			0.92				0.99	1.07	1.16	1.34	1.52	1.52	1.52	1.52	1.52	
00139	10 x 3-1/2"		3.5			2	207	224	240	261	302	357	421	421	421	421
			0.92				0.99	1.07	1.16	1.34	1.59	1.87	1.87	1.87	1.87	
00141	10 x 4"	3.875	2.625	207	224	240	261	302	357	477	553	553	553			
		0.92		0.99	1.07	1.16	1.34	1.59	2.12	2.46	2.46	2.46				
00143	10 x 4-3/4"	4.625	3	207	224	240	261	302	357	477	596	632	632			
		0.92		0.99	1.07	1.16	1.34	1.59	2.12	2.65	2.81	2.81				

MODEL/ BULK PART NO.	R4 NOMINAL DIA.	SHANK DIAMETER (in.)	SCREW LENGTH (in.)	HEAD DIAMETER (in.)	OUTSIDE THREAD DIAMETER (in.)	THREAD LENGTH (in.)	POINT-SIDE MEMBER SPECIES: S-P-F SAWN LUMBER									
							SIDE MEMBER: COLD-FORMED STEEL THICKNESS OF SIDE MEMBER (in.)									
							20 GA.	18 GA.	16 GA.	14 GA.	12 GA.	20 GA.	18 GA.	16 GA.	14 GA.	12 GA.
							LATERAL RESISTANCE					WITHDRAWAL RESISTANCE				
							LB.	LB.	LB.	LB.	LB.	LB.	LB.	LB.	LB.	LB.
kN	kN	kN	kN	kN	kN	kN	kN	kN	kN							
00133	10 x 2-1/2"	0.142	2.375	0.368	0.193	1.625	188	204	221	242	276	260	260	260	260	260
			0.84				0.91	0.98	1.07	1.23	1.16	1.16	1.16	1.16	1.16	
00135	10 x 2-3/4"		2.75			1.875	188	204	221	242	276	301	301	301	301	301
			0.84				0.91	0.98	1.07	1.23	1.34	1.34	1.34	1.34	1.34	
00137	10 x 3-1/8"		3.125			1.625	188	204	221	242	276	260	260	260	260	260
			0.84				0.91	0.98	1.07	1.23	1.16	1.16	1.16	1.16	1.16	
00139	10 x 3-1/2"		3.5			2	188	204	221	242	276	321	321	421	321	321
			0.84				0.91	0.98	1.07	1.23	1.43	1.43	1.43	1.43	1.43	
00141	10 x 4"	3.875	2.625	188	204	221	242	276	357	421	421	421	421			
		0.84		0.91	0.98	1.07	1.23	1.59	1.87	1.87	1.87	1.87				
00143	10 x 4-3/4"	4.625	3	188	204	221	242	276	357	477	481	481	481			
		0.84		0.91	0.98	1.07	1.23	1.59	2.12	2.14	2.14	2.14				

<sup>1</sup> Resistance values have been developed in accordance with Clause 12.11 "Wood Screws" CSA 086-14 and have been factored with the material resistance factor ( $\phi$ ). No other modification factors affecting resistance have been applied. Values must be multiplied by all applicable modification factors as specified for wood screws in accordance with CSA 086-14.

<sup>2</sup> ICC ESR-3201 report can be referred to for information not provided in this table. Note that resistance values of GRK R4 screw connections with cold-formed steel, mild steel and plywood side members have not been developed in the ICC ESR-3201 report.

<sup>3</sup> Multiply lateral resistance values by 0.83 for toe-screw installation and by 0.67 for end-grain installation. Toe-screw and end-grain installations are not permitted for screws loaded in withdrawal.

<sup>4</sup> Minimum row spacing, spacing in row and edge distances, penetration lengths, and member thicknesses shall be as specified in Clause 12.11.2 CSA 086-14. The minimum spacing table provided in this catalogue can be used for reference.

<sup>5</sup> '---' indicates the screw cannot be used for the resistance due to the screw length not meeting the minimum penetration length into the point-side member. Resistance values have been developed assuming the screw is fully penetrated into the point-side member.

<sup>6</sup> Resistance values with mild steel side member have been developed for mild steel referenced in CSA S16 (ASTM A36/A36M steel;  $f_u = 400$  MPa). Resistance values with cold-formed steel side member have been developed for cold-formed steel light gauge steel referenced in CSA S136 (Grade SS 230;  $f_u = 310$  MPa).

<sup>7</sup> Convert inches to millimetres by multiplying the value by 25.4 (1 in. = 25.4 mm).

# R4™ Multi-Purpose Framing Screws

## GRK R4 10xL MILD STEEL SIDE PL

MODEL/ BULK PART NO.	R4 NOMINAL DIA.	SHANK DIAMETER (in.)	SCREW LENGTH (in.)	HEAD DIAMETER (in.)	OUTSIDE THREAD DIAMETER (in.)	THREAD LENGTH (in.)	POINT-SIDE MEMBER SPECIES: D.FIR-L SAWN LUMBER									
							SIDE MEMBER: MILD STEEL THICKNESS OF SIDE MEMBER (in.)									
							1/8	9/64	3/16	1/4	1/2	1/8	9/64	3/16	1/4	1/2
							LATERAL RESISTANCE					WITHDRAWAL RESISTANCE				
							LB.	LB.	LB.	LB.	LB.	LB.	LB.	LB.	LB.	LB.
00133	10 x 2-1/2"	0.142	2.375	0.368	0.193	1.625	322	322	322	322	322	342	342	342	342	342
			1.43				1.43	1.43	1.43	1.43	1.52	1.52	1.52	1.52	1.52	
00135	10 x 2-3/4"		2.75			1.875	322	322	322	315	395	395	395	395	395	
			1.43				1.43	1.43	1.43	1.43	1.76	1.76	1.76	1.76		
00137	10 x 3-1/8"		3.125			1.625	322	322	322	322	342	342	342	342	342	
			1.43				1.43	1.43	1.43	1.43	1.52	1.52	1.52	1.52		
00139	10 x 3-1/2"		3.5			2	322	322	322	322	421	421	421	421	421	
			1.43				1.43	1.43	1.43	1.43	1.87	1.87	1.87	1.87		
00141	10 x 4"	3.875	2.625	322	322	322	322	553	553	553	553	553				
		1.43		1.43	1.43	1.43	1.43	2.46	2.46	2.46	2.46					
00143	10 x 4-3/4"	4.625	3	322	322	322	322	632	632	632	632	632				
		1.43		1.43	1.43	1.43	1.43	2.81	2.81	2.81	2.81					

MODEL/ BULK PART NO.	R4 NOMINAL DIA.	SHANK DIAMETER (in.)	SCREW LENGTH (in.)	HEAD DIAMETER (in.)	OUTSIDE THREAD DIAMETER (in.)	THREAD LENGTH (in.)	POINT-SIDE MEMBER SPECIES: S-P-F SAWN LUMBER									
							SIDE MEMBER: MILD STEEL THICKNESS OF SIDE MEMBER (in.)									
							1/8	9/64	3/16	1/4	1/2	1/8	9/64	3/16	1/4	1/2
							LATERAL RESISTANCE					WITHDRAWAL RESISTANCE				
							LB.	LB.	LB.	LB.	LB.	LB.	LB.	LB.	LB.	LB.
00133	10 x 2-1/2"	0.142	2.375	0.368	0.193	1.625	281	281	281	281	281	260	260	260	260	260
			1.25				1.25	1.25	1.25	1.25	1.16	1.16	1.16	1.16		
00135	10 x 2-3/4"		2.75			1.875	281	281	281	281	301	301	301	301	301	
			1.25				1.25	1.25	1.25	1.25	1.34	1.34	1.34	1.34		
00137	10 x 3-1/8"		3.125			1.625	281	281	281	281	260	260	260	260	260	
			1.25				1.25	1.25	1.25	1.25	1.16	1.16	1.16	1.16		
00139	10 x 3-1/2"		3.5			2	281	281	281	281	321	321	321	321	321	
			1.25				1.25	1.25	1.25	1.25	1.43	1.43	1.43	1.43		
00141	10 x 4"	3.875	2.625	281	281	281	281	421	421	421	421	421				
		1.25		1.25	1.25	1.25	1.25	1.87	1.87	1.87	1.87					
00143	10 x 4-3/4"	4.625	3	281	281	281	281	481	481	481	481	481				
		1.25		1.25	1.25	1.25	1.25	2.14	2.14	2.14	2.14					

<sup>1</sup> Resistance values have been developed in accordance with Clause 12.11 "Wood Screws" CSA 086-14 and have been factored with the material resistance factor ( $\phi$ ). No other modification factors affecting resistance have been applied. Values must be multiplied by all applicable modification factors as specified for wood screws in accordance with CSA 086-14.

<sup>2</sup> ICC ESR-3201 report can be referred to for information not provided in this table. Note that resistance values of GRK R4 screw connections with cold-formed steel, mild steel and plywood side members have not been developed in the ICC ESR-3201 report.

<sup>3</sup> Multiply lateral resistance values by 0.83 for toe-screw installation and by 0.67 for end-grain installation. Toe-screw and end-grain installations are not permitted for screws loaded in withdrawal.

<sup>4</sup> Minimum row spacing, spacing in row and edge distances, penetration lengths, and member thicknesses shall be as specified in Clause 12.11.2 CSA 086-14. The minimum spacing table provided in this catalogue can be used for reference.

<sup>5</sup> '---' indicates the screw cannot be used for the resistance due to the screw length not meeting the minimum penetration length into the point-side member. Resistance values have been developed assuming the screw is fully penetrated into the point-side member.

<sup>6</sup> Resistance values with mild steel side member have been developed for mild steel referenced in CSA S16 (ASTM A36/A36M steel;  $f_u = 400$  MPa). Resistance values with cold-formed steel side member have been developed for cold-formed steel light gauge steel referenced in CSA S136 (Grade SS 230;  $f_u = 310$  MPa).

<sup>7</sup> Convert inches to millimetres by multiplying the value by 25.4 (1 in. = 25.4 mm).

## GRK R4 12xL D.FIR-L SAWN LUMBER SIDE PL

MODEL/ BULK PART NO.	R4 NOMINAL DIA.	SHANK DIAMETER (in.)	SCREW LENGTH (in.)	HEAD DIAMETER (in.)	OUTSIDE THREAD DIAMETER (in.)	THREAD LENGTH (in.)	POINT-SIDE MEMBER: D.FIR-L SAWN LUMBER										
							SIDE MEMBER: D.FIR-L SAWN LUMBER THICKNESS OF SIDE MEMBER (in.)										
							1.5	2	2.5	3	3.5	4	4.5	5	6	8	
							LATERAL RESISTANCE										
LB.		LB.		LB.		LB.		LB.		LB.		LB.		LB.			
kN		kN		kN		kN		kN		kN		kN		kN			
00165	12 x 4"	0.171	4.625	0.439	0.234	3	291	304	304	303	257	---	---	---	---	---	
							1.30	1.35	1.35	1.35	1.14	---	---	---	---	---	
00173	12 x 5-5/8"		5.5			3	291	304	304	304	304	291	245	---	---	---	---
							1.30	1.35	1.35	1.35	1.35	1.30	1.09	---	---	---	
00177	12 x 6-3/8"		6.25			3	291	304	304	304	304	304	304	268	---	---	---
							1.30	1.35	1.35	1.35	1.35	1.35	1.35	1.19	---	---	
00179	12 x 7-1/4"		7			3	291	304	304	304	304	304	304	304	304	245	---
							1.30	1.35	1.35	1.35	1.35	1.35	1.35	1.35	1.35	1.09	---
00181	12 x 8"		7.875			3	291	304	304	304	304	304	304	304	304	304	---
							1.30	1.35	1.35	1.35	1.35	1.35	1.35	1.35	1.35	1.35	---
02187	12 x 10"	9.75	3	291	304	304	304	304	304	304	304	304	304	304			
				1.30	1.35	1.35	1.35	1.35	1.35	1.35	1.35	1.35	1.35	1.35			
02193	12 x 12"	11.75	3	291	304	304	304	304	304	304	304	304	304	304			
				1.30	1.35	1.35	1.35	1.35	1.35	1.35	1.35	1.35	1.35	1.35			

MODEL/ BULK PART NO.	R4 NOMINAL DIA.	SHANK DIAMETER (in.)	SCREW LENGTH (in.)	HEAD DIAMETER (in.)	OUTSIDE THREAD DIAMETER (in.)	THREAD LENGTH (in.)	POINT-SIDE MEMBER: D.FIR-L SAWN LUMBER									
							SIDE MEMBER: D.FIR-L SAWN LUMBER THICKNESS OF SIDE MEMBER (in.)									
							1.5	2	2.5	3	3.5	4	4.5	5	6	8
							WITHDRAWAL RESISTANCE									
LB.		LB.		LB.		LB.		LB.		LB.		LB.		LB.		
kN		kN		kN		kN		kN		kN		kN		kN		
00165	12 x 4"	0.171	4.625	0.439	0.234	3	223	297	371	401	277	---	---	---	---	---
							0.99	1.32	1.65	1.78	1.23	---	---	---	---	---
00173	12 x 5-5/8"		5.5			3	223	297	371	445	493	370	247	---	---	---
							0.99	1.32	1.65	1.98	2.19	1.65	1.10	---	---	---
00177	12 x 6-3/8"		6.25			3	223	297	371	445	520	555	432	308	---	---
							0.99	1.32	1.65	1.98	2.31	2.47	1.92	1.37	---	---
00179	12 x 7-1/4"		7			3	223	297	371	445	520	594	617	493	247	---
							0.99	1.32	1.65	1.98	2.31	2.64	2.74	2.19	1.10	---
00181	12 x 8"		7.875			3	223	297	371	445	520	594	668	709	462	---
							0.99	1.32	1.65	1.98	2.31	2.64	2.97	3.15	2.06	---
02187	12 x 10"	9.75	3	223	297	371	445	520	594	668	740	740	432			
				0.99	1.32	1.65	1.98	2.31	2.64	2.97	3.29	3.29	1.92			
02193	12 x 12"	11.75	3	223	297	371	445	520	594	668	740	740	740			
				0.99	1.32	1.65	1.98	2.31	2.64	2.97	3.29	3.29	3.29			

<sup>1</sup> Resistance values have been developed in accordance with Clause 12.11 "Wood Screws" CSA 086-14 and have been factored with the material resistance factor ( $\phi$ ). No other modification factors affecting resistance have been applied. Values must be multiplied by all applicable modification factors as specified for wood screws in accordance with CSA 086-14.

<sup>2</sup> ICC ESR-3201 report can be referred to for information not provided in this table. Note that resistance values of GRK R4 screw connections with cold-formed steel, mild steel and plywood side members have not been developed in the ICC ESR-3201 report.

<sup>3</sup> Multiply lateral resistance values by 0.83 for toe-screw installation and by 0.67 for end-grain installation. Toe-screw and end-grain installations are not permitted for screws loaded in withdrawal.

<sup>4</sup> Minimum row spacing, spacing in row and edge distances, penetration lengths, and member thicknesses shall be as specified in Clause 12.11.2 CSA 086-14. The minimum spacing table provided in this catalogue can be used for reference.

<sup>5</sup> '---' indicates the screw cannot be used for the resistance due to the screw length not meeting the minimum penetration length into the point-side member. Resistance values have been developed assuming the screw is fully penetrated into the point-side member.

<sup>6</sup> Resistance values with mild steel side member have been developed for mild steel referenced in CSA S16 (ASTM A36/A36M steel;  $f_u = 400$  MPa). Resistance values with cold-formed steel side member have been developed for cold-formed steel light gauge steel referenced in CSA S136 (Grade SS 230;  $f_u = 310$  MPa).

<sup>7</sup> Convert inches to millimetres by multiplying the value by 25.4 (1 in. = 25.4 mm).

# R4™ Multi-Purpose Framing Screws

## GRK R4 12xL SPF SAWN LUMBER SIDE PL

MODEL/ BULK PART NO.	R4 NOMINAL DIA.	SHANK DIAMETER (in.)	SCREW LENGTH (in.)	HEAD DIAMETER (in.)	OUTSIDE THREAD DIAMETER (in.)	THREAD LENGTH (in.)	POINT-SIDE MEMBER: S-P-F SAWN LUMBER											
							SIDE MEMBER: S-P-F SAWN LUMBER THICKNESS OF SIDE MEMBER (in.)											
							1.5	2	2.5	3	3.5	4	4.5	5	6	8		
							LATERAL RESISTANCE											
							LB. kN	LB. kN	LB. kN	LB. kN	LB. kN	LB. kN	LB. kN	LB. kN	LB. kN	LB. kN		
00165	12 x 4"	0.171	4.625	0.439	0.234	3	256	273	273	266	226	---	---	---	---	---		
							1.14	1.22	1.22	1.18	1.01	---	---	---	---	---		
00173	12 x 5-5/8"		5.5			5.5	3	256	273	273	273	273	256	216	---	---	---	---
								1.14	1.22	1.22	1.22	1.22	1.14	0.96	---	---	---	
00177	12 x 6-3/8"		6.25			6.25	3	256	273	273	273	273	273	273	236	---	---	---
								1.14	1.22	1.22	1.22	1.22	1.22	1.22	1.05	---	---	
00179	12 x 7-1/4"		7			7	3	256	273	273	273	273	273	273	273	216	---	---
								1.14	1.22	1.22	1.22	1.22	1.22	1.22	1.22	0.96	---	
00181	12 x 8"		7.875			7.875	3	256	273	273	273	273	273	273	273	273	---	---
								1.14	1.22	1.22	1.22	1.22	1.22	1.22	1.22	1.22	---	
02187	12 x 10"	9.75	9.75	3	256	273	273	273	273	273	273	273	273	273	273			
					1.14	1.22	1.22	1.22	1.22	1.22	1.22	1.22	1.22	1.22				
02193	12 x 12"	11.75	11.75	3	256	273	273	273	273	273	273	273	273	273	273			
					1.14	1.22	1.22	1.22	1.22	1.22	1.22	1.22	1.22	1.22				

MODEL/ BULK PART NO.	R4 NOMINAL DIA.	SHANK DIAMETER (in.)	SCREW LENGTH (in.)	HEAD DIAMETER (in.)	OUTSIDE THREAD DIAMETER (in.)	THREAD LENGTH (in.)	POINT-SIDE MEMBER: S-P-F SAWN LUMBER											
							SIDE MEMBER: S-P-F SAWN LUMBER THICKNESS OF SIDE MEMBER (in.)											
							1.5	2	2.5	3	3.5	4	4.5	5	6	8		
							WITHDRAWAL RESISTANCE											
							LB. kN	LB. kN	LB. kN	LB. kN	LB. kN	LB. kN	LB. kN	LB. kN	LB. kN	LB. kN		
00165	12 x 4"	0.171	4.625	0.439	0.234	3	223	297	371	305	211	---	---	---	---	---		
							0.99	1.32	1.65	1.36	0.94	---	---	---	---	---		
00173	12 x 5-5/8"		5.5			5.5	3	223	297	371	445	375	282	188	---	---	---	---
								0.99	1.32	1.65	1.98	1.67	1.25	0.84	---	---	---	
00177	12 x 6-3/8"		6.25			6.25	3	223	297	371	445	516	422	329	235	---	---	---
								0.99	1.32	1.65	1.98	2.30	1.88	1.46	1.04	---	---	
00179	12 x 7-1/4"		7			7	3	223	297	371	445	520	563	469	375	188	---	---
								0.99	1.32	1.65	1.98	2.31	2.51	2.09	1.67	0.84	---	
00181	12 x 8"		7.875			7.875	3	223	297	371	445	520	563	563	540	352	---	---
								0.99	1.32	1.65	1.98	2.31	2.51	2.51	2.40	1.57	---	
02187	12 x 10"	9.75	9.75	3	223	297	371	445	520	563	563	563	563	329	---			
					0.99	1.32	1.65	1.98	2.31	2.51	2.51	2.51	2.51	1.46				
02193	12 x 12"	11.75	11.75	3	223	297	371	445	520	563	563	563	563	563	563			
					0.99	1.32	1.65	1.98	2.31	2.51	2.51	2.51	2.51	2.51				

<sup>1</sup> Resistance values have been developed in accordance with Clause 12.11 "Wood Screws" CSA 086-14 and have been factored with the material resistance factor ( $\phi$ ). No other modification factors affecting resistance have been applied. Values must be multiplied by all applicable modification factors as specified for wood screws in accordance with CSA 086-14.

<sup>2</sup> ICC ESR-3201 report can be referred to for information not provided in this table. Note that resistance values of GRK R4 screw connections with cold-formed steel, mild steel and plywood side members have not been developed in the ICC ESR-3201 report.

<sup>3</sup> Multiply lateral resistance values by 0.83 for toe-screw installation and by 0.67 for end-grain installation. Toe-screw and end-grain installations are not permitted for screws loaded in withdrawal.

<sup>4</sup> Minimum row spacing, spacing in row and edge distances, penetration lengths, and member thicknesses shall be as specified in Clause 12.11.2 CSA 086-14. The minimum spacing table provided in this catalogue can be used for reference.

<sup>5</sup> '---' indicates the screw cannot be used for the resistance due to the screw length not meeting the minimum penetration length into the point-side member. Resistance values have been developed assuming the screw is fully penetrated into the point-side member.

<sup>6</sup> Resistance values with mild steel side member have been developed for mild steel referenced in CSA S16 (ASTM A36/A36M steel;  $f_u = 400$  MPa). Resistance values with cold-formed steel side member have been developed for cold-formed steel light gauge steel referenced in CSA S136 (Grade SS 230;  $f_u = 310$  MPa).

<sup>7</sup> Convert inches to millimetres by multiplying the value by 25.4 (1 in. = 25.4 mm).

## GRK R4 12xL PLYWOOD SIDE PL

MODEL/ BULK PART NO.	R4 NOMINAL DIA.	SHANK DIAMETER (in.)	SCREW LENGTH (in.)	HEAD DIAMETER (in.)	OUTSIDE THREAD DIAMETER (in.)	THREAD LENGTH (in.)	POINT-SIDE MEMBER: D.FIR-L SAWN LUMBER							
							SIDE MEMBER: DFP PANEL THICKNESS OF SIDE MEMBER (in.)							
							3/8	1/2	5/8	3/4	3/8	1/2	5/8	3/4
							LATERAL RESISTANCE				WITHDRAWAL RESISTANCE			
							LB. kN	LB. kN	LB. kN	LB. kN	LB. kN	LB. kN	LB. kN	LB. kN
00165	12 x 4"	0.171	4.625	0.439	0.234	3	203	218	232	246	56	74	93	111
							0.90	0.97	1.03	1.10	0.25	0.33	0.41	0.50
00173	12 x 5-5/8"		5.5			203	218	232	246	56	74	93	111	
										0.90	0.97	1.03	1.10	0.25
00177	12 x 6-3/8"		6.25			203	218	232	246	56	74	93	111	
										0.90	0.97	1.03	1.10	0.25
00179	12 x 7-1/4"		7			203	218	232	246	56	74	93	111	
										0.90	0.97	1.03	1.10	0.25
00181	12 x 8"	7.875	203	218	232	246	56	74	93	111				
							0.90	0.97	1.03	1.10	0.25	0.33	0.41	0.50
02187	12 x 10"	9.75	203	218	232	246	56	74	93	111				
							0.90	0.97	1.03	1.10	0.25	0.33	0.41	0.50
02193	12 x 12"	11.75	203	218	232	246	56	74	93	111				
							0.90	0.97	1.03	1.10	0.25	0.33	0.41	0.50

MODEL/ BULK PART NO.	R4 NOMINAL DIA.	SHANK DIAMETER (in.)	SCREW LENGTH (in.)	HEAD DIAMETER (in.)	OUTSIDE THREAD DIAMETER (in.)	THREAD LENGTH (in.)	POINT-SIDE MEMBER: S-P-F SAWN LUMBER							
							SIDE MEMBER: CSP PLYWOOD THICKNESS OF SIDE MEMBER (in.)							
							3/8	1/2	5/8	3/4	3/8	1/2	5/8	3/4
							LATERAL RESISTANCE				WITHDRAWAL RESISTANCE			
							LB. kN	LB. kN	LB. kN	LB. kN	LB. kN	LB. kN	LB. kN	LB. kN
00165	12 x 4"	0.171	4.625	0.439	0.234	3	181	193	205	217	56	74	93	111
							0.80	0.86	0.91	0.97	0.25	0.33	0.41	0.50
00173	12 x 5-5/8"		5.5			181	193	205	217	56	74	93	111	
										0.80	0.86	0.91	0.97	0.25
00177	12 x 6-3/8"		6.25			181	193	205	217	56	74	93	111	
										0.80	0.86	0.91	0.97	0.25
00179	12 x 7-1/4"		7			181	193	205	217	56	74	93	111	
										0.80	0.86	0.91	0.97	0.25
00181	12 x 8"	7.875	181	193	205	217	56	74	93	111				
							0.80	0.86	0.91	0.97	0.25	0.33	0.41	0.50
02187	12 x 10"	9.75	181	193	205	217	56	74	93	111				
							0.80	0.86	0.91	0.97	0.25	0.33	0.41	0.50
02193	12 x 12"	11.75	181	193	205	217	56	74	93	111				
							0.80	0.86	0.91	0.97	0.25	0.33	0.41	0.50

<sup>1</sup> Resistance values have been developed in accordance with Clause 12.11 "Wood Screws" CSA 086-14 and have been factored with the material resistance factor ( $\phi$ ). No other modification factors affecting resistance have been applied. Values must be multiplied by all applicable modification factors as specified for wood screws in accordance with CSA 086-14.

<sup>2</sup> ICC ESR-3201 report can be referred to for information not provided in this table. Note that resistance values of GRK R4 screw connections with cold-formed steel, mild steel and plywood side members have not been developed in the ICC ESR-3201 report.

<sup>3</sup> Multiply lateral resistance values by 0.83 for toe-screw installation and by 0.67 for end-grain installation. Toe-screw and end-grain installations are not permitted for screws loaded in withdrawal.

<sup>4</sup> Minimum row spacing, spacing in row and edge distances, penetration lengths, and member thicknesses shall be as specified in Clause 12.11.2 CSA 086-14. The minimum spacing table provided in this catalogue can be used for reference.

<sup>5</sup> '---' indicates the screw cannot be used for the resistance due to the screw length not meeting the minimum penetration length into the point-side member. Resistance values have been developed assuming the screw is fully penetrated into the point-side member.

<sup>6</sup> Resistance values with mild steel side member have been developed for mild steel referenced in CSA S16 (ASTM A36/A36M steel;  $f_u = 400$  MPa). Resistance values with cold-formed steel side member have been developed for cold-formed steel light gauge steel referenced in CSA S136 (Grade SS 230;  $f_u = 310$  MPa).

<sup>7</sup> Convert inches to millimetres by multiplying the value by 25.4 (1 in. = 25.4 mm).

# R4™ Multi-Purpose Framing Screws

## GRK R4 12xL COLD-FORMED STEEL SIDE PL

MODEL/ BULK PART NO.	R4 NOMINAL DIA.	SHANK DIAMETER (in.)	SCREW LENGTH (in.)	HEAD DIAMETER (in.)	OUTSIDE THREAD DIAMETER (in.)	THREAD LENGTH (in.)	POINT-SIDE MEMBER: D.FIR-L SAWN LUMBER										
							SIDE MEMBER: COLD-FORMED STEEL THICKNESS OF SIDE MEMBER (in.)										
							20 GA.	18 GA.	16 GA.	14 GA.	12 GA.	20 GA.	18 GA.	16 GA.	14 GA.	12 GA.	
							LATERAL RESISTANCE					WITHDRAWAL RESISTANCE					
							LB.	LB.	LB.	LB.	LB.	LB.	LB.	LB.	LB.	LB.	
kN	kN	kN	kN	kN	kN	kN	kN	kN	kN								
00165	12 x 4"	0.171	4.625	0.439	0.234	3	280	300	320	345	394	426	568	711	740	740	
							1.24	1.33	1.42	1.53	1.75	1.90	2.53	3.16	3.29	3.29	
00173	12 x 5-5/8"		5.5			5.5	3	280	300	320	345	394	426	568	711	740	740
								1.24	1.33	1.42	1.53	1.75	1.90	2.53	3.16	3.29	3.29
00177	12 x 6-3/8"		6.25			6.25	3	280	300	320	345	394	426	568	711	740	740
								1.24	1.33	1.42	1.53	1.75	1.90	2.53	3.16	3.29	3.29
00179	12 x 7-1/4"		7			7	3	280	307	320	345	394	426	568	711	740	740
								1.24	1.37	1.42	1.53	1.75	1.90	2.53	3.16	3.29	3.29
00181	12 x 8"		7.875			7.875	3	280	300	320	345	394	426	568	711	740	740
								1.24	1.33	1.42	1.53	1.75	1.90	2.53	3.16	3.29	3.29
02187	12 x 10"	9.75	9.75	3	280	300	320	345	394	426	568	711	740	740			
					1.24	1.33	1.42	1.53	1.75	1.90	2.53	3.16	3.29	3.29			
02193	12 x 12"	11.75	11.75	3	280	300	320	345	394	426	568	711	740	740			
					1.24	1.33	1.42	1.53	1.75	1.90	2.53	3.16	3.29	3.29			

MODEL/ BULK PART NO.	R4 NOMINAL DIA.	SHANK DIAMETER (in.)	SCREW LENGTH (in.)	HEAD DIAMETER (in.)	OUTSIDE THREAD DIAMETER (in.)	THREAD LENGTH (in.)	POINT-SIDE MEMBER: S-P-F SAWN LUMBER										
							SIDE MEMBER: COLD-FORMED STEEL THICKNESS OF SIDE MEMBER (in.)										
							20 GA.	18 GA.	16 GA.	14 GA.	12 GA.	20 GA.	18 GA.	16 GA.	14 GA.	12 GA.	
							LATERAL RESISTANCE					WITHDRAWAL RESISTANCE					
							LB.	LB.	LB.	LB.	LB.	LB.	LB.	LB.	LB.	LB.	
kN	kN	kN	kN	kN	kN	kN	kN	kN	kN								
00165	12 x 4"	0.171	4.625	0.439	0.234	3	253	273	293	318	367	426	563	563	563	563	
							1.12	1.21	1.30	1.41	1.63	1.90	2.51	2.51	2.51	2.51	
00173	12 x 5-5/8"		5.5			5.5	3	253	273	293	318	367	426	563	563	563	563
								1.12	1.21	1.30	1.41	1.63	1.90	2.51	2.51	2.51	2.51
00177	12 x 6-3/8"		6.25			6.25	3	253	273	293	318	367	426	563	563	563	563
								1.12	1.21	1.30	1.41	1.63	1.90	2.51	2.51	2.51	2.51
00179	12 x 7-1/4"		7			7	3	253	273	293	318	367	426	563	563	563	563
								1.12	1.21	1.30	1.41	1.63	1.90	2.51	2.51	2.51	2.51
00181	12 x 8"		7.875			7.875	3	253	273	293	318	367	426	563	563	563	563
								1.12	1.21	1.30	1.41	1.63	1.90	2.51	2.51	2.51	2.51
02187	12 x 10"	9.75	9.75	3	253	273	293	318	367	426	563	563	563	563			
					1.12	1.21	1.30	1.41	1.63	1.90	2.51	2.51	2.51	2.51			
02193	12 x 12"	11.75	11.75	3	253	273	293	318	367	426	563	563	563	563			
					1.12	1.21	1.30	1.41	1.63	1.90	2.51	2.51	2.51	2.51			

<sup>1</sup> Resistance values have been developed in accordance with Clause 12.11 "Wood Screws" CSA 086-14 and have been factored with the material resistance factor ( $\phi$ ). No other modification factors affecting resistance have been applied. Values must be multiplied by all applicable modification factors as specified for wood screws in accordance with CSA 086-14.

<sup>2</sup> ICC ESR-3201 report can be referred to for information not provided in this table. Note that resistance values of GRK R4 screw connections with cold-formed steel, mild steel and plywood side members have not been developed in the ICC ESR-3201 report.

<sup>3</sup> Multiply lateral resistance values by 0.83 for toe-screw installation and by 0.67 for end-grain installation. Toe-screw and end-grain installations are not permitted for screws loaded in withdrawal.

<sup>4</sup> Minimum row spacing, spacing in row and edge distances, penetration lengths, and member thicknesses shall be as specified in Clause 12.11.2 CSA 086-14. The minimum spacing table provided in this catalogue can be used for reference.

<sup>5</sup> '---' indicates the screw cannot be used for the resistance due to the screw length not meeting the minimum penetration length into the point-side member. Resistance values have been developed assuming the screw is fully penetrated into the point-side member.

<sup>6</sup> Resistance values with mild steel side member have been developed for mild steel referenced in CSA S16 (ASTM A36/A36M steel;  $f_u = 400$  MPa). Resistance values with cold-formed steel side member have been developed for cold-formed steel light gauge steel referenced in CSA S136 (Grade SS 230;  $f_u = 310$  MPa).

<sup>7</sup> Convert inches to millimetres by multiplying the value by 25.4 (1 in. = 25.4 mm).

## GRK R4 12xL MILD STEEL SIDE PL

MODEL/ BULK PART NO.	R4 NOMINAL DIA.	SHANK DIAMETER (in.)	SCREW LENGTH (in.)	HEAD DIAMETER (in.)	OUTSIDE THREAD DIAMETER (in.)	THREAD LENGTH (in.)	POINT-SIDE MEMBER: D.FIR-L SAWN LUMBER									
							SIDE MEMBER: MILD STEEL THICKNESS OF SIDE MEMBER (in.)									
							1/8	9/64	3/16	1/4	1/2	1/8	9/64	3/16	1/4	1/2
							LATERAL RESISTANCE					WITHDRAWAL RESISTANCE				
							LB. kN	LB. kN	LB. kN	LB. kN	LB. kN	LB. kN	LB. kN	LB. kN	LB. kN	LB. kN
00165	12 x 4"	0.171	4.625	0.439	0.234	3	450	450	450	450	450	740	740	740	740	740
							2.00	2.00	2.00	2.00	2.00	3.29	3.29	3.29	3.29	3.29
00173	12 x 5-5/8"		5.5			3	450	450	450	450	450	740	740	740	740	740
							2.00	2.00	2.00	2.00	2.00	3.29	3.29	3.29	3.29	3.29
00177	12 x 6-3/8"		6.25			3	450	450	450	450	450	740	740	740	740	740
							2.00	2.00	2.00	2.00	2.00	3.29	3.29	3.29	3.29	3.29
00179	12 x 7-1/4"		7			3	450	450	450	450	450	740	740	740	740	740
							2.00	2.00	2.00	2.00	2.00	3.29	3.29	3.29	3.29	3.29
00181	12 x 8"		7.875			3	450	450	450	450	450	740	740	740	740	740
							2.00	2.00	2.00	2.00	2.00	3.29	3.29	3.29	3.29	3.29
02187	12 x 10"	9.75	3	450	450	450	450	450	740	740	740	740	740			
				2.00	2.00	2.00	2.00	2.00	3.29	3.29	3.29	3.29	3.29			
02193	12 x 12"	11.75	3	450	450	450	450	450	740	740	740	740	740			
				2.00	2.00	2.00	2.00	2.00	3.29	3.29	3.29	3.29	3.29			

MODEL/ BULK PART NO.	R4 NOMINAL DIA.	SHANK DIAMETER (in.)	SCREW LENGTH (in.)	HEAD DIAMETER (in.)	OUTSIDE THREAD DIAMETER (in.)	THREAD LENGTH (in.)	POINT-SIDE MEMBER: S-P-F SAWN LUMBER									
							SIDE MEMBER: MILD STEEL THICKNESS OF SIDE MEMBER (in.)									
							1/8	9/64	3/16	1/4	1/2	1/8	9/64	3/16	1/4	1/2
							LATERAL RESISTANCE					WITHDRAWAL RESISTANCE				
							LB. kN	LB. kN	LB. kN	LB. kN	LB. kN	LB. kN	LB. kN	LB. kN	LB. kN	LB. kN
00165	12 x 4"	0.171	4.625	0.439	0.234	3	368	392	392	392	392	550	563	563	563	563
							1.64	1.75	1.75	1.75	1.75	2.45	2.51	2.51	2.51	2.51
00173	12 x 5-5/8"		5.5			3	368	392	392	392	392	550	563	563	563	563
							1.64	1.75	1.75	1.75	1.75	2.45	2.51	2.51	2.51	2.51
00177	12 x 6-3/8"		6.25			3	368	392	392	392	392	550	563	563	563	563
							1.64	1.75	1.75	1.75	1.75	2.45	2.51	2.51	2.51	2.51
00179	12 x 7-1/4"		7			3	368	392	392	392	392	550	563	563	563	563
							1.64	1.75	1.75	1.75	1.75	2.45	2.51	2.51	2.51	2.51
00181	12 x 8"		7.875			3	368	392	392	392	392	550	563	563	563	563
							1.64	1.75	1.75	1.75	1.75	2.45	2.51	2.51	2.51	2.51
02187	12 x 10"	9.75	3	368	392	392	392	392	550	563	563	563	563			
				1.64	1.75	1.75	1.75	1.75	2.45	2.51	2.51	2.51	2.51			
02193	12 x 12"	11.75	3	368	392	392	392	392	550	563	563	563	563			
				1.64	1.75	1.75	1.75	1.75	2.45	2.51	2.51	2.51	2.51			

<sup>1</sup> Resistance values have been developed in accordance with Clause 12.11 "Wood Screws" CSA 086-14 and have been factored with the material resistance factor ( $\phi$ ). No other modification factors affecting resistance have been applied. Values must be multiplied by all applicable modification factors as specified for wood screws in accordance with CSA 086-14.

<sup>2</sup> ICC ESR-3201 report can be referred to for information not provided in this table. Note that resistance values of GRK R4 screw connections with cold-formed steel, mild steel and plywood side members have not been developed in the ICC ESR-3201 report.

<sup>3</sup> Multiply lateral resistance values by 0.83 for toe-screw installation and by 0.67 for end-grain installation. Toe-screw and end-grain installations are not permitted for screws loaded in withdrawal.

<sup>4</sup> Minimum row spacing, spacing in row and edge distances, penetration lengths, and member thicknesses shall be as specified in Clause 12.11.2 CSA 086-14. The minimum spacing table provided in this catalogue can be used for reference.

<sup>5</sup> '---' indicates the screw cannot be used for the resistance due to the screw length not meeting the minimum penetration length into the point-side member. Resistance values have been developed assuming the screw is fully penetrated into the point-side member.

<sup>6</sup> Resistance values with mild steel side member have been developed for mild steel referenced in CSA S16 (ASTM A36/A36M steel;  $f_u = 400$  MPa). Resistance values with cold-formed steel side member have been developed for cold-formed steel light gauge steel referenced in CSA S136 (Grade SS 230;  $f_u = 310$  MPa).

<sup>7</sup> Convert inches to millimetres by multiplying the value by 25.4 (1 in. = 25.4 mm).

## Speedy Lag Bolt Alternative with Immense Drawing Power



### DESCRIPTION/SUGGESTED SPECIFICATIONS

#### Rugged Structural Screws—

GRK's RSS™ screw is made of specially hardened steel to provide you with high tensile, torque and shear strength. The sharp threads and points bite instantly into the material (including hardwood), reducing the splitting effect due to smaller shanks.

RSS™ screws that are 3" 1/8" and longer have CEE Threads which enlarge the screw hole for the non-threaded portion of the fastener, allowing the wood to settle easily and increases the screw's drawing strength. The CEE Thread also reduces the friction on the screw shank which can result in lowering the driving torque and the likelihood of splitting the wood. This is why the RSS™ screw is an efficient lag screw alternative.

#### ÜberGrade™



Our round head with built-in shield (washer type head) has no sharp edges like conventional lag screws. The added shoulder (nominal diameter) underneath the washer has the ability to center the RSS™ screw in pre-drilled hardware like hinges and connector plates.

**NEW! RSS™ Black:** Designed for an architectural finish

RSS™ JTS - Used for joists and trusses

RSS™ LTF - Designed for log home and timber frame

### ADVANTAGES

- **Recessed Star Drive:** Zero Stripping, with 6 points of contact.
- **CEE Thread:** Enlarges hole to reduce splitting, install torque.
- **W-Cut™:** Low torque, smoother drive, reduce splitting.
- **Zip-Tip™:** No pre-drilling, faster penetration, reduce splitting.
- **Washer Head:** for immense holding power.
- **Cutting Pockets:** provide a clean hole, reduces splitting, and bore with precision.
- **ESR-2442 Approved** for structural application.
- **Case Hardened Steel:** for high tensile, torque and shear strength.
- **Climatek™ Coating** is AC257 code approved for use in treated lumber.
- For interior/exterior use in; carrying beams, ledger boards, stair rails, deck posts, playground equipment and other professional applications.
- **Advantages:** Factored Resistances as per CSA 086-14

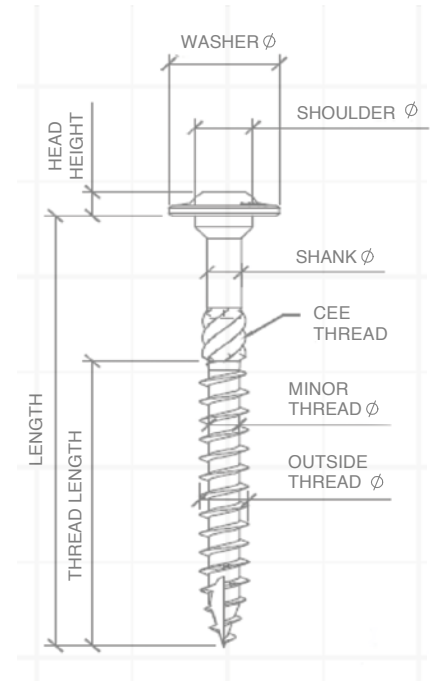







### APPROVALS/LISTING





## RSS™ Rugged Structural Screws

### SELECTION CHART

	SHANK DIAMETER	THREAD DIAMETER	LENGTH	BULK PART NO.	BULK BOX QTY.	PRO-PAK PART NO.	PRO-PAK PAIL QTY.	HANDY-PAK PART NO.	HANDY-PAK CTN. SIZE/QTY.
 T-25	0.138	0.194 (#10)	1-1/2"	10127*	2,300				
			2-3/4"	10135	1,000				
			3-1/8"	10137	800			12137	M/50
 T-25	0.169	0.25 (1/4)	1-1/2"	10151*	1,000			12151	M/50
			2"	10155*	800			12155	M/50
			2-1/2"	10157	700			12157	M/50
			3-1/8"	10161	500			12161	M/50
			3-1/2"	10163	400			12163	M/50
 T-30	0.1988	0.3125 (5/16)	2-1/2"	10217	600	12217	100		
			2-3/4"	10219	500	12219	100		
			3-1/8"	10221	500	12221	100		
			3-1/2"	10223	500	12223	100		
			4"	10225	400	12225	100		
			5-1/8"	10231	300	12231	50		
			6"	10235	300	12235	50		
 T-40	0.2228	0.375 (3/8")	3-1/8"	10273	400	12273	50		
			4"	10275	400	12275	50		
			5-1/8"	10278	300	12278	50		
			6"	10281	300	12281	50		
			7-1/4"	10285	200	12285	50		
			8"	10287	300	12287	50		
			10"	10293	300	12293	50		
			12"	10299	300	12299	50		
			14-1/8"	10307	200	12307	50		
16"	10311	100	12311	50					
<b>RSS™ JTS – JOIST AND TRUSS SCREW</b>									
 T-25	0.173	0.25 (1/4)	3-3/8"	91727†	400				
			5"	91735	300				
<b>RSS™ LTF – TIMBER FRAME SCREW</b>									
 T-40	0.22	0.31 (3/8)	8"	91287	300			93287	M/50
			10"	91293	300			93293	M/50
			12"	91299	300			93299	M/50
			15"	91308	300			93308	M/50
			20"					93323	M/25

NEW! Black RSS™				
SHANK DIAMETER	THREAD DIAMETER	LENGTH	Part No.	QTY
0.1988	0.3125 (5/16)	2-3/4"	16219	100
		4"	16225	100
		5-1/8"	16231	50
		6"	16235	50

NEW! Black RSS™				
SHANK DIAMETER	THREAD DIAMETER	LENGTH	Part No.	QTY
0.22	0.31 (3/8)	5-1/8"	16278	50
		8"	16287	50
		10"	16293	50

RSS™ BLISTER-PAK				
SHANK DIAMETER	THREAD DIAMETER	LENGTH	Part No.	QTY
0.1988	0.3125 (5/16)	3-1/8"	13221	15
		4"	13225	12
		5-1/8"	13231	10
		6"	13235	8

RSS™ SMALLER HANDY-PAK				
SHANK DIAMETER	THREAD DIAMETER	LENGTH	Part No.	QTY
0.1988	0.3125 (5/16)	3-1/8"	14221	M/25
		4"	14225	M/25
		5-1/8"	14231	M/20
		6"	14235	M/20

**NOTE:** Pro-Paks need to be ordered in multiples of two.

\*Does not come with the Zip-Tip™ feature. †Does not have the added CEE-THREAD™ feature. 2" bit included in Pro-Paks, 1" bits in Handy-Paks.

## GRK RSS vs. Lag Bolt

No more pre-drilling... Just grab a screw and drill!!

## Convert from a lag screw to GRK RSS Fasteners

### PERFORMANCE DATA

(Compliant for use with Canadian National Building Code)

FACTORED RESISTANCES PERFORMANCE COMPARISON FOR D.FIR MEMBERS<sup>(1,2,3,4,5)</sup>  
APPLICATION: 2" LEDGER BOARD TO 2" RIM BOARD (LBS)

LAG SCREWS				GRK SCREWS		
LAG SIZE	LENGTH	SHEAR RESISTANCE	PULL-OUT	TYPE OF SCREW	SHEAR RESISTANCE	PULL-OUT
1/4"	3	171	360	GRK RSS (3") (10273)	366	517
1/4"	4	200	360	GRK RSS (4") (10275)	466	517
3/8"	3	249	618	GRK RSS (3") (10273)	366	517
3/8"	4	322	618	GRK RSS (4") (10275)	466	517
1/2"	3	320	779	GRK RSS (3") (10273)	366	517
1/2"	4	427	779	GRK RSS (4") (10275)	466	517
5/8"	3	385	920	GRK RSS (3") (10273)	366	517
5/8"	4	513	920	GRK RSS (4") (10275)	466	517

<sup>1</sup> Lag Screw Factored Resistances have been developed in accordance with 12.6 CSA 086-14. Apply adjustment factors where applicable.

<sup>2</sup> Factored withdrawn resistance shown assume the entire threaded portion of the screw is installed in to the main member

<sup>3</sup> Minimum spacing, edge and end distances shall be in accordance with 12.6 .2 CSA 086-14

<sup>4</sup> GRK RSS Screw spacing must comply with 12.11.5 CSA 086-14 (See Spacing Tables)

<sup>5</sup> Dimensions of Lag screw based on Table 15 & 16 ASME B18.2.1-2012

### EXAMPLE DECK DESIGN: ATTACHING LEDGER BOARD TO YOUR HOUSE!

#### Assumptions:

- Deck Span = 8' out from the house
- 10' Wide
- LL = 40 PSF; DL = 10 PSF

Total lateral resistance required = 2900 lbs

#### Possible Solutions:

Using 1/4" by 3" Lag Bolts =  $2900 / 242 = 12$  lags

Using 3/8" by 3" Lag Bolts =  $2900 / 249 = 12$  Lags (see example below)

Using 1/2" by 3" Lag Bolts =  $2900 / 320 = 9$

Using 5/8" by 3" Lag Bolts =  $2900 / 385 = 8$

Using 3/8" \* 3.125 RSS =  $2900 / 366 = 8$  screws (see example below)

#### LAG SOLUTION: 12 LAG SCREWS

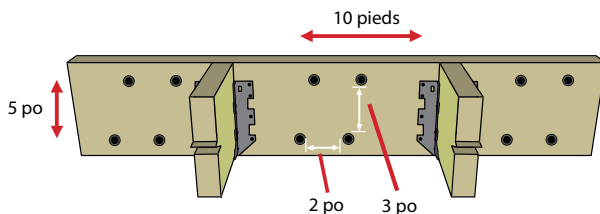

#### RSS SOLUTION: 8 RSS SCREWS<sup>1</sup> NO PRE-DRILLING

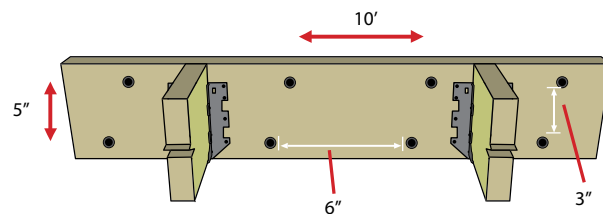

<sup>1</sup> RSS Spacing must comply with 12.11.5 CSA 086-14

## GRK RSS Spacings

MINIMUM ROW SPACING, SPACING IN ROW AND EDGE DISTANCES AS SPECIFIED IN CLAUSE 12.11.2 CSA 086 2016.

SCREW THREAD DIAMETER (IN.)	SCREW SHANK DIAMETER (IN.)	GEOMETRY	MINIMUM DIMENSIONS (in)	
			D. FIR-L	S-P-F
1/4	0.169	a - Spacing parallel to grain	3.4	2.7
		b - End distance parallel to grain	2.5	2.0
		c - Spacing perpendicular to grain	1.7	1.4
		d - Edge distance perpendicular to grain	0.8	0.7

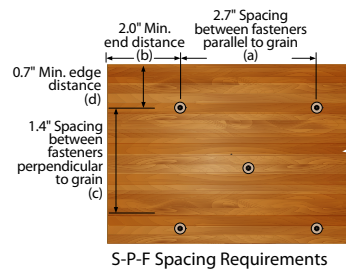
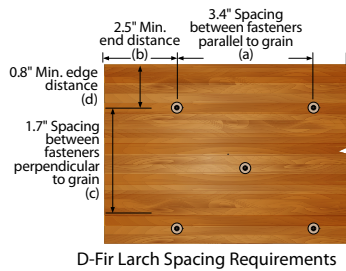

SCREW THREAD DIAMETER (IN.)	SCREW SHANK DIAMETER (IN.)	GEOMETRY	MINIMUM DIMENSIONS (in)	
			D. FIR-L	S-P-F
5/16	0.1988	a - Spacing parallel to grain	4.0	3.2
		b - End distance parallel to grain	3.0	2.4
		c - Spacing perpendicular to grain	2.0	1.6
		d - Edge distance perpendicular to grain	1.0	0.8

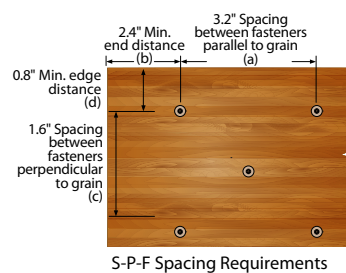
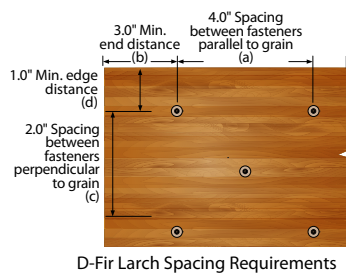

SCREW THREAD DIAMETER (IN.)	SCREW SHANK DIAMETER (IN.)	GEOMETRY	MINIMUM DIMENSIONS (in)	
			D. FIR-L	S-P-F
3/8	0.2228	a - Spacing parallel to grain	4.5	3.6
		b - End distance parallel to grain	3.3	2.7
		c - Spacing perpendicular to grain	2.2	1.8
		d - Edge distance perpendicular to grain	1.1	0.9

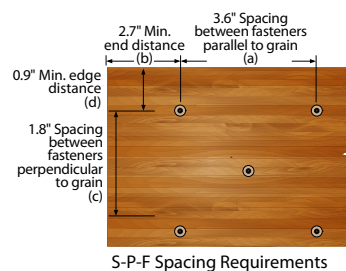
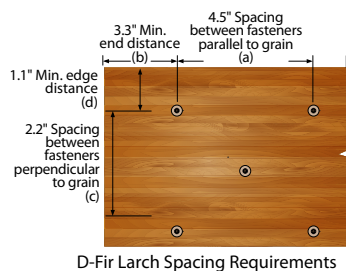

1. Table values have been developed in accordance to Clause 12.6.2.6 CSA 086 2016. Designer to note additional provision in Clause 12 in CSA 086 2016 for service conditions and other factors affecting connection layout and capacity.

# RSS™ Rugged Structural Screws

## Factored Resistances (RSS 1/4")

### FACTORED RESISTANCES FOR D.FIR MEMBERS

MODEL/ BULK PART NO.	SIZE		SHANK DIAMETER	THREADED LENGTH (in)	D-FIR-L										
	THREAD DIA (in)	LENGTH (in)			FACTORED LATERAL RESISTANCE WOOD SIDE MEMBER THICKNESS (in)										FACTORED WITHDRAWAL
					1.5	2	2.5	3	3.5	4	4.5	5	6	8	
					LB.	LB.	LB.	LB.	LB.	LB.	LB.	LB.	LB.	LB.	
kN	kN	kN	kN	kN	kN	kN	kN	kN	kN	kN	kN				
10217	1/4	2.5	0.169	1.5	230*	---	---	---	---	---	---	---	---	---	332
					1.02*	---	---	---	---	---	---	---	---	---	1.48
22400		3.125		2	287	259	---	---	---	---	---	---	---	---	457
					1.28	1.15	---	---	---	---	---	---	---	---	2.03
10163		3.5		2.75	305	305	230*	---	---	---	---	---	---	---	646
					1.36	1.36	1.02*	---	---	---	---	---	---	---	2.87

### FACTORED RESISTANCES FOR S-P-F MEMBERS (LBS)

MODEL/ BULK PART NO.	SIZE		SHANK DIAMETER	THREADED LENGTH (in)	SPF										
	THREAD DIA (in)	LENGTH (in)			FACTORED LATERAL RESISTANCE WOOD SIDE MEMBER THICKNESS (in)										FACTORED WITHDRAWAL
					1.5	2	2.5	3	3.5	4	4.5	5	6	8	
					LB.	LB.	LB.	LB.	LB.	LB.	LB.	LB.	LB.	LB.	
kN	kN	kN	kN	kN	kN	kN	kN	kN	kN	kN	kN				
10217	1/4	2.5	0.169	1.5	197*	---	---	---	---	---	---	---	---	---	253
					0.88*	---	---	---	---	---	---	---	---	---	1.12
22400		3.125		2	246	222	---	---	---	---	---	---	---	---	348
					1.10	0.99	---	---	---	---	---	---	---	---	1.55
10163		3.5		2.75	268	268	197*	---	---	---	---	---	---	---	491
					1.19	1.19	0.88*	---	---	---	---	---	---	---	2.19

<sup>1</sup> End-grain installation is not permitted.

<sup>2</sup> Factored lateral resistances shown have been developed in accordance with Clause 12.11 CSA O86 2016 **Wood Screw** provisions. Values must be multiplied by all applicable modification factors as specified for **wood screws** in accordance with CSA O86 2016.

<sup>3</sup> Factored lateral resistances according to Clause 12.6 CSA O86 2016 **Lag Screw** provisions can be obtained upon request. Please contact ITW Canada for more information. Designer to note provisions for net area and group of fasteners per Clause 12 in CSA O86 2016.

<sup>4</sup> Factored withdrawal resistances shown have been developed in accordance with Clause 12.6 CSA O86 2016 **Lag Screw** provisions. Values must be multiplied by all applicable modification factors as specified for **lag screws** in accordance with CSA O86 2016.

<sup>5</sup> Factored withdrawal resistances shown assume the entire threaded portion of the screw is installed into the main member. This accounts for the tip length reduction as per 12.6 CSA O86 2016 **Lag Screw** provisions.

<sup>6</sup> Minimum row spacing, spacing in row and edge distances shall be as specified in Clause 12.6.2.6 CSA O86 2016. Designer to note additional provision in Clause 12 in CSA O86 2016 for service conditions and other factors affecting connection layout and capacity. The minimum spacing table can be used for reference.

\*The penetration length is less than the minimum as per Lag Screw provision but it meets the penetration length according to the Wood Screw provision on Clause 12 of CSA O86 2016. See footnote 6.

<sup>7</sup> Convert inches to millimetres by multiplying the value by 25.4 (1 in. = 25.4 mm).

## Factored Resistances (RSS 5/16")

### FACTORED RESISTANCES FOR D.FIR MEMBERS

MODEL/ BULK PART NO.	SIZE		SHANK DIAMETER	THREADED LENGTH (in)	D-FIR-L										FACTORED WITHDRAWAL						
	THREAD DIA (in)	LENGTH (in)			FACTORED LATERAL RESISTANCE WOOD SIDE MEMBER THICKNESS (in)																
					1.5	2	2.5	3	3.5	4	4.5	5	6	8							
					LB.	LB.	LB.	LB.	LB.	LB.	LB.	LB.	LB.	LB.		LB.					
											kN	kN	kN	kN	kN	kN	kN	kN	kN	kN	kN
10217	5/16	2.5	0.1988	1.5	268*	---	---	---	---	---	---	---	---	---	---	378					
					1.19*	---	---	---	---	---	---	---	---	---	---	1.68					
10219		2.75		1.75	295	---	---	---	---	---	---	---	---	---	---	449					
					1.31	---	---	---	---	---	---	---	---	---	---	2.00					
10221		3.125		2.125	335	302*	---	---	---	---	---	---	---	---	---	556					
					1.49	1.34*	---	---	---	---	---	---	---	---	---	2.47					
10223		3.5		2.5	376	376	268*	---	---	---	---	---	---	---	---	664					
					1.67	1.67	1.19*	---	---	---	---	---	---	---	---	2.95					
10225		4		2.75	404	429	402	268*	---	---	---	---	---	---	---	735					
					1.80	1.91	1.79	1.19*	---	---	---	---	---	---	---	3.27					
10231	5.125	3.5	404	459	488	472	418	302*	---	---	---	---	---	949							
			1.80	2.04	2.17	2.10	1.86	1.34*	---	---	---	---	---	4.22							
10235	6	3.875	404	459	488	488	488	459	402	268*	---	---	---	1056							
			1.80	2.04	2.17	2.17	2.17	2.04	1.79	1.19*	---	---	---	4.70							

### FACTORED RESISTANCES FOR S-P-F MEMBERS (LBS)

MODEL/ BULK PART NO.	SIZE		SHANK DIAMETER	THREADED LENGTH (in)	SPF										FACTORED WITHDRAWAL						
	THREAD DIA (in)	LENGTH (in)			FACTORED LATERAL RESISTANCE WOOD SIDE MEMBER THICKNESS (in)																
					1.5	2	2.5	3	3.5	4	4.5	5	6	8							
					LB.	LB.	LB.	LB.	LB.	LB.	LB.	LB.	LB.	LB.		LB.					
											kN	kN	kN	kN	kN	kN	kN	kN	kN	kN	kN
10217	5/16	2.5	0.1988	1.5	230*	---	---	---	---	---	---	---	---	---	---	288					
					1.02*	---	---	---	---	---	---	---	---	---	---	1.28					
10219		2.75		1.75	253	---	---	---	---	---	---	---	---	---	---	342					
					1.13	---	---	---	---	---	---	---	---	---	---	1.52					
10221		3.125		2.125	287	259*	---	---	---	---	---	---	---	---	---	454					
					1.28	1.15*	---	---	---	---	---	---	---	---	---	1.88					
10223		3.5		2.5	322	322	230*	---	---	---	---	---	---	---	---	505					
					1.43	1.43	1.02*	---	---	---	---	---	---	---	---	2.25					
10225		4		2.75	357	368	345	230*	---	---	---	---	---	---	---	559					
					1.59	1.64	1.53	1.02*	---	---	---	---	---	---	---	2.49					
10231	5.125	3.5	357	403	439	415	369	259*	---	---	---	---	---	723							
			1.59	1.79	1.95	1.85	1.64	1.15*	---	---	---	---	---	3.21							
10235	6	3.875	357	403	439	439	439	403	345	230*	---	---	---	804							
			1.59	1.79	1.95	1.95	1.95	1.79	1.53	1.02*	---	---	---	3.58							

- <sup>1</sup> End-grain installation is not permitted.
- <sup>2</sup> Factored lateral resistances shown have been developed in accordance with Clause 12.11 CSA O86 2016 **Wood Screw** provisions. Values must be multiplied by all applicable modification factors as specified for **wood screws** in accordance with CSA O86 2016.
- <sup>3</sup> Factored lateral resistances according to Clause 12.6 CSA O86 2016 **Lag Screw** provisions can be obtained upon request. Please contact ITW Canada for more information. Designer to note provisions for net area and group of fasteners per Clause 12 in CSA O86 2016.
- <sup>4</sup> Factored withdrawal resistances shown have been developed in accordance with Clause 12.6 CSA O86 2016 **Lag Screw** provisions. Values must be multiplied by all applicable modification factors as specified for **lag screws** in accordance with CSA O86 2016.
- <sup>5</sup> Factored withdrawal resistances shown assume the entire threaded portion of the screw is installed into the main member. This accounts for the tip length reduction as per 12.6 CSA O86 2016 **Lag Screw** provisions.
- <sup>6</sup> Minimum row spacing, spacing in row and edge distances shall be as specified in Clause 12.6.2.6 CSA O86 2016. Designer to note additional provision in Clause 12 in CSA O86 2016 for service conditions and other factors affecting connection layout and capacity. The minimum spacing table can be used for reference.  
\*The penetration length is less than the minimum as per Lag Screw provision but it meets the penetration length according to the Wood Screw provision on Clause 12 of CSA O86 2016. See footnote 6.
- <sup>7</sup> Convert inches to millimetres by multiplying the value by 25.4 (1 in. = 25.4 mm).

## Factored Resistances (RSS 3/8")

### FACTORED RESISTANCES FOR D.FIR MEMBERS

MODEL/ BULK PART NO.	SIZE		SHANK DIAMETER	THREADED LENGTH (in)	D-FIR-L												
	THREAD DIA (in)	LENGTH (in)			FACTORED LATERAL RESISTANCE WOOD SIDE MEMBER THICKNESS (in)										FACTORED WITHDRAWAL		
					1.5	2	2.5	3	3.5	4	4.5	5	6	8			
					LB.	LB.	LB.	LB.	LB.	LB.	LB.	LB.	LB.	LB.		LB.	
kN	kN	kN	kN	kN	kN	kN	kN	kN	kN	kN	kN						
10273	3/8	3.125	0.2228	1.5	373	336*	---	---	---	---	---	---	---	---	---	403	
					1.66	1.50*	---	---	---	---	---	---	---	---	---	1.79	
10275		4		2.75	474	478	448	---	---	---	---	---	---	---	---	---	791
					2.11	2.13	1.99	---	---	---	---	---	---	---	---	3.52	
10278		5.125		3.5	474	534	590	549	486	336*	---	---	---	---	---	---	1024
					2.11	2.37	2.62	2.44	2.16	1.50*	---	---	---	---	---	4.56	
10281		6		4	474	534	590	590	590	534	448	---	---	---	---	---	1180
					2.11	2.37	2.62	2.62	2.62	2.37	1.99	---	---	---	---	5.25	
10285		7.25		4.5	474	534	590	590	590	590	590	564	373*	---	---	---	1335
					2.11	2.37	2.62	2.62	2.62	2.62	2.62	2.51	1.66*	---	---	5.94	
10287		8		4.375	474	534	590	590	590	590	590	590	534	---	---	---	1335
					2.11	2.37	2.62	2.62	2.62	2.62	2.62	2.62	2.62	2.37	---	---	5.94
10293		10		5	474	534	590	590	590	590	590	590	590	534	---	---	1490
					2.11	2.37	2.62	2.62	2.62	2.62	2.62	2.62	2.62	2.62	2.37	---	6.63
10299		12		5.875	474	534	590	590	590	590	590	590	590	590	---	---	1762
					2.11	2.37	2.62	2.62	2.62	2.62	2.62	2.62	2.62	2.62	2.62	---	7.84
10307	14.125	5.875	474	534	590	590	590	590	590	590	590	590	---	---	1762		
			2.11	2.37	2.62	2.62	2.62	2.62	2.62	2.62	2.62	2.62	2.62	---	7.84		
10311	16	5.75	474	534	590	590	590	590	590	590	590	590	---	---	1762		
			2.11	2.37	2.62	2.62	2.62	2.62	2.62	2.62	2.62	2.62	2.62	---	7.84		

<sup>1</sup> End-grain installation is not permitted.

<sup>2</sup> Factored lateral resistances shown have been developed in accordance with Clause 12.11 CSA 086 2016 **Wood Screw** provisions. Values must be multiplied by all applicable modification factors as specified for **wood screws** in accordance with CSA 086 2016.

<sup>3</sup> Factored lateral resistances according to Clause 12.6 CSA 086 2016 **Lag Screw** provisions can be obtained upon request. Please contact ITW Canada for more information. Designer to note provisions for net area and group of fasteners per Clause 12 in CSA 086 2016.

<sup>4</sup> Factored withdrawal resistances shown have been developed in accordance with Clause 12.6 CSA 086 2016 **Lag Screw** provisions. Values must be multiplied by all applicable modification factors as specified for **lag screws** in accordance with CSA 086 2016.

<sup>5</sup> Factored withdrawal resistances shown assume the entire threaded portion of the screw is installed into the main member. This accounts for the tip length reduction as per 12.6 CSA 086 2016 **Lag Screw** provisions.

<sup>6</sup> Minimum row spacing, spacing in row and edge distances shall be as specified in Clause 12.6.2.6 CSA 086 2016. Designer to note additional provision in Clause 12 in CSA 086 2016 for service conditions and other factors affecting connection layout and capacity. The minimum spacing table can be used for reference.

\*The penetration length is less than the minimum as per Lag Screw provision but it meets the penetration length according to the Wood Screw provision on Clause 12 of CSA 086 2016. See footnote 6.

<sup>7</sup> Convert inches to millimetres by multiplying the value by 25.4 (1 in. = 25.4 mm).

Factored Resistances (RSS 3/8") continued on page G 15

## Factored Resistances (RSS 3/8")

### FACTORED RESISTANCES FOR S-P-F MEMBERS (LBS)

MODEL/ BULK PART NO.	SIZE		SHANK DIAMETER	THREADED LENGTH (in)	SPF												
	THREAD DIA (in)	LENGTH (in)			FACTORED LATERAL RESISTANCE WOOD SIDE MEMBER THICKNESS (in)										FACTORED WITHDRAWAL		
					1.5	2	2.5	3	3.5	4	4.5	5	6	8			
					LB.	LB.	LB.	LB.	LB.	LB.	LB.	LB.	LB.	LB.		LB.	
kN	kN	kN	kN	kN	kN	kN	kN	kN	kN	kN	kN						
10273	3/8	3.125	0.2228	1.5	320	288*	---	---	---	---	---	---	---	---	---	307	
					1.42	1.28*	---	---	---	---	---	---	---	---	---	1.37	
10275		4		2.75	410	410	410	---	---	---	---	---	---	---	---	---	602
					1.82	1.82	1.82	---	---	---	---	---	---	---	---	2.68	
10278		5.125		3.5	419	470	521	483	416	288*	---	---	---	---	---	---	780
					1.86	2.09	2.32	2.15	1.85	1.28*	---	---	---	---	---	3.47	
10281		6		4	419	470	521	531	521	470	384	---	---	---	---	---	898
					1.86	2.09	2.32	2.36	2.32	2.09	1.71	---	---	---	---	3.99	
10285		7.25		4.5	419	470	521	531	531	531	531	496	320*	---	---	---	1016
					1.86	2.09	2.32	2.36	2.36	2.36	2.36	2.36	2.21	1.42*	---	---	4.52
10287		8		4.375	419	470	521	531	531	531	531	531	470	---	---	---	1016
					1.86	2.09	2.32	2.36	2.36	2.36	2.36	2.36	2.36	2.09	---	---	4.52
10293		10		5	419	470	521	531	531	531	531	531	531	470	---	---	1134
					1.86	2.09	2.32	2.36	2.36	2.36	2.36	2.36	2.36	2.36	2.09	---	5.04
10299		12		5.875	419	470	521	531	531	531	531	531	531	531	531	---	1341
					1.86	2.09	2.32	2.36	2.36	2.36	2.36	2.36	2.36	2.36	2.36	2.36	5.96
10307	14.125	5.875	419	470	521	531	531	531	531	531	531	531	531	---	1341		
			1.86	2.09	2.32	2.36	2.36	2.36	2.36	2.36	2.36	2.36	2.36	2.36	5.96		
10311	16	5.75	419	470	521	531	531	531	531	531	531	531	531	---	1341		
			1.86	2.09	2.32	2.36	2.36	2.36	2.36	2.36	2.36	2.36	2.36	2.36	5.96		

<sup>1</sup> End-grain installation is not permitted.

<sup>2</sup> Factored lateral resistances shown have been developed in accordance with Clause 12.11 CSA 086 2016 **Wood Screw** provisions. Values must be multiplied by all applicable modification factors as specified for **wood screws** in accordance with CSA 086 2016.

<sup>3</sup> Factored lateral resistances according to Clause 12.6 CSA 086 2016 **Lag Screw** provisions can be obtained upon request. Please contact ITW Canada for more information. Designer to note provisions for net area and group of fasteners per Clause 12 in CSA 086 2016.

<sup>4</sup> Factored withdrawal resistances shown have been developed in accordance with Clause 12.6 CSA 086 2016 **Lag Screw** provisions. Values must be multiplied by all applicable modification factors as specified for **lag screws** in accordance with CSA 086 2016.

<sup>5</sup> Factored withdrawal resistances shown assume the entire threaded portion of the screw is installed into the main member. This accounts for the tip length reduction as per 12.6 CSA 086 2016 **Lag Screw** provisions.

<sup>6</sup> Minimum row spacing, spacing in row and edge distances shall be as specified in Clause 12.6.2.6 CSA 086 2016. Designer to note additional provision in Clause 12 in CSA 086 2016 for service conditions and other factors affecting connection layout and capacity. The minimum spacing table can be used for reference.

\*The penetration length is less than the minimum as per Lag Screw provision but it meets the penetration length according to the Wood Screw provision on Clause 12 of CSA 086 2016. See footnote 6.

<sup>7</sup> Convert inches to millimetres by multiplying the value by 25.4 (1 in. = 25.4 mm).

**Heads Blend in  
with Decking.  
No Mushrooming  
Effect**



**DESCRIPTION/SUGGESTED SPECIFICATIONS**

**Composite Deck Screws—**

GRK's Kameleon™ screws are an excellent choice for composite and PVC decking applications. The underhead has saw-blade like cutting teeth that cut a perfectly clean hole into the decking.

The Kameleon™ also features five to seven rings that have three indented fibre traps on each ring designed to trap fibres and eliminate the mushroom effect.

**ÜberGrade™**



The CEE Thread feature enlarges the screw hole allowing the composite decking to settle easily, increases the screw's drawing strength, and reduces the friction on the screw shank, which can result in lowering the overall driving torque.

The Kameleon™ is also available in many different colors including: Grey, Brown, and Tan.

**ADVANTAGES**

- **Recessed Star Drive:** Zero Stripping, with 6 points of contact.
- **CEE Thread:** Enlarges hole to reduce splitting, install torque.
- **W-Cut™:** Low torque, smoother drive, reduce splitting.
- **Zip-Tip™:** No pre-drilling, faster penetration, reduce splitting.
- **Fibre Trapping Rings:** are designed to prevent mushrooming and dimpling.
- **Cutting Pockets:** provide a clean hole, reduces splitting, and bore with precision.
- **ESR-3201 Approved** for structural application.
- **Case Hardened Steel:** for high tensile, torque and shear strength.
- **Climatek™ Coating** is AC257 code approved for use in treated lumber.
- For interior/exterior use in; both composite and PVC decking.

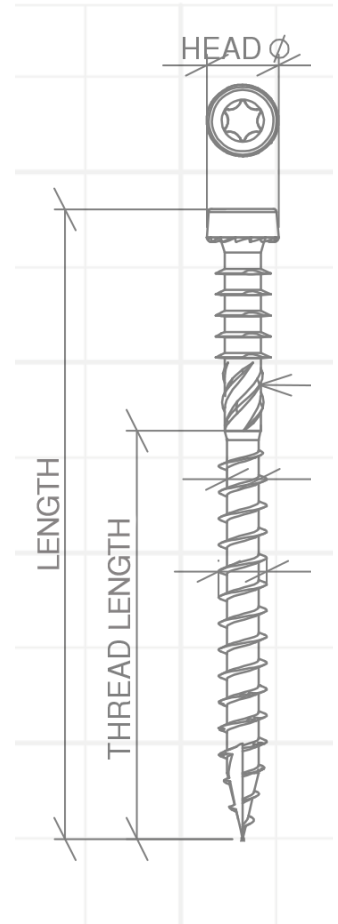

**APPROVALS/LISTING**





## Kameleon™ Composite Deck Screws

### SELECTION CHART



T-20

Grey  
Tan  
Brown

U.S. (STD.) SIZE (DIA. X LENGTH)	METRIC SIZE (DIA. X LENGTH)	HANDY-PAK PART NO.	HANDY-PAK CTN. SIZE/QTY.
#9 x 2-1/2"	4.5 x 63	67151	M/100
#9 x 2-1/2"	4.5 x 63	67155	M/100
#9 x 2-1/2"	4.5 x 63	67158	M/100



**NOTE:** 1" bits in Handy-Paks.

**Smallest Head on  
the Market for a  
Clean Finish**



**DESCRIPTION/SUGGESTED SPECIFICATIONS**

**Finishing Trim Head Screws—**

GRK's Trim™ Head screws are an excellent choice for most fine carpentry applications, as well as window extension jambs and more. Our Trim™ Head screws have the smallest screw head available; with screw lengths from 1-1/4" (30 mm) to 5" (125 mm).

**ÜberGrade™**

Most material splitting is prevented because of the Trim™ Head screw's exceptionally small head and the W-Cut thread design.

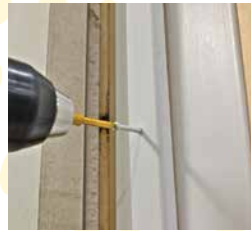

Fin/Trim™ screws are also available in white Climatek™ coated finish to blend in with white wooden trim boards.

**ADVANTAGES**

- **Recessed Star Drive:** Zero Stripping, with 6 points of contact.
- **Trim Head:** for a clean finished look.
- **W-Cut™:** Low torque, smoother drive.
- **Zip-Tip™:** No pre-drilling, faster penetration.
- **ESR-3201 Approved** for structural application.
- **Case Hardened Steel:** for high tensile, torque and shear strength.
- **Climatek™ Coating is AC257** code approved for use in treated lumber.
- For interior/exterior use.
- Available in **Climatek™** or white powder coated finish.

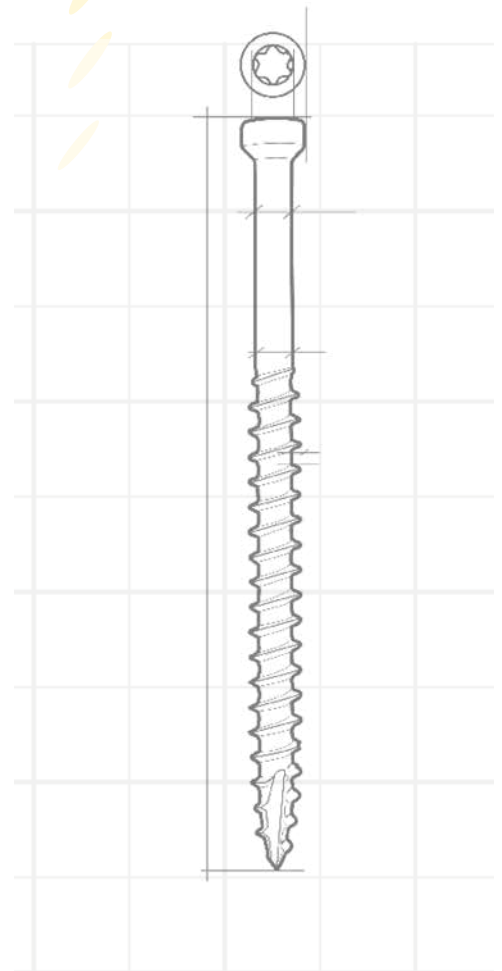

**APPROVALS/LISTING**



## Fin/Trim™ Finishing Trim Head Screws

### SELECTION CHART

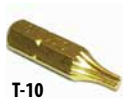

T-10



T-15



T-10

U.S. (STD.) SIZE (DIA. X LENGTH)	METRIC SIZE (DIA. X LENGTH)	BULK PART NO.	BULK BOX QTY.	PRO-PAK PART NO.	PRO-PAK PAIL QTY.	HANDY-PAK PART NO.	HANDY-PAK CTN. SIZE/QTY.
#8 x 1-1/4"	4.0 x 30					17720	S/100
#8 x 1-1/2"	4.0 x 40					17724	S/100
#8 x 2"	4.0 x 50					17728	S/100
#8 x 2-1/2"	4.0 x 63	15730	3,500	16730	605	17730	S/100
#8 x 2-3/4"	4.0 x 70					17732	S/100
#8 x 3-1/8"	4.0 x 80	15734	2,500			17734	M/100
#9 x 3-1/8"	4.5 x 80	15756	1,900				
#9 x 4"	4.5 x 100	15760	1,000			17760	M/100
#9 x 5"	4.5 x 125					17766	M/100
<b>WHITE FIN/TRIM™</b>							
#8 x 2-1/2"	4.0 x 63	15830	3,500			17830	S/100

**Excellent for all of your trimwork and fine carpentry finishing.**



**NOTE:** Pro-Paks need to be ordered in multiples of two. 2" bit included in Pro-Paks, 1" bits in Handy-Paks.

## Reverse Thread Design Prevents Mushrooming



### DESCRIPTION/SUGGESTED SPECIFICATIONS

#### Exterior Trim Screws—

GRK has modified its innovative FIN/Trim™ Head screw to include reverse threading under the head of the fastener. This technology makes the RT Composite™ Trim Screw ideal for use in composite and cellular PVC trim.

#### ÜberGrade™



Based on extensive tests, GRK has found that the reverse thread helps the screw head disappear beneath the surface of the classic wood composite material, reducing or eliminating the dimple that sometimes appears when using the FIN/Trim™ screw.

The reverse thread feature is available in RT Composite™ screws from 2" to 3-1/8" in length in both regular Climatek™ coating and in white Climatek™ coated finish to blend in with popular white exterior composite and cellular PVC trim.

### ADVANTAGES

- **Recessed Star Drive:** Zero Stripping, with 6 points of contact.
- **Reverse Threads** eliminate mushrooming.
- **Trim Head:** for a clean finished look.
- **W-Cut™:** Low torque, smoother drive and reduce splitting.
- **Zip-Tip™:** No pre-drilling, faster penetration and reduce splitting.
- **ESR-3201 Approved** for structural application.
- **Case Hardened Steel:** for high tensile, torque and shear strength.
- **Climatek™ Coating is AC257 code approved** for use in treated lumber.
- For interior/exterior use in; exterior PVC trim (Azek, Kleer, Koma), no pre-drilling is necessary. Climatek™ coated screws work well with CAMO system.
- Available in **Climatek™** or white powder coated finish.

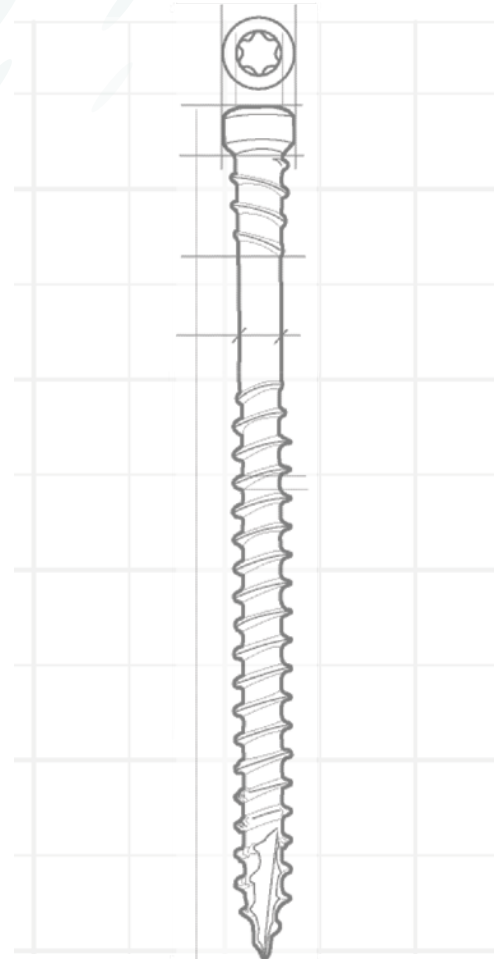

### APPROVALS/LISTING



## RT Composite™ Exterior Trim Screws

### SELECTION CHART



T-10

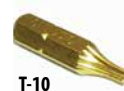

T-10

U.S. (STD.) SIZE (DIA. X LENGTH)	METRIC SIZE (DIA. X LENGTH)	BULK PART NO.	BULK BOX QTY.	PRO-PAK PART NO.	PRO-PAK PAIL QTY.	HANDY-PAK PART NO.	HANDY-PAK CTN. SIZE/QTY.
#8 x 2"	4.0 x 50					17077	S/100
#8 x 2-1/2"	4.0 x 63	15079	3,500	16079	605	17079	S/100
#8 x 3-1/8"	4.0 x 80	15083	2,500				
<b>WHITE RT COMPOSITE™</b>							
#8 x 2-1/2"	4.0 x 63					17630	S/100

**Supreme Drawing Power is perfect for trimwork and deck construction.**



**NOTE:** Pro-Paks need to be ordered in multiples of two. 2" bit included in Pro-Paks, 1" bits in Handy-Paks.

## Built-in Washer Head Presses Flush Against any Material



### DESCRIPTION/SUGGESTED SPECIFICATIONS

#### Cabinet Screws—

GRK's Cabinet™ screws are designed specifically for use in cabinet construction and installation. Cabinet™ screws are manufactured in a #8 gauge (4 mm) diameter for universal size convenience.

These screws are thin enough to prevent most material splitting, while providing sufficient strength to guarantee a secure installation. The washer head design presses flush against any material surface.

#### ÜberGrade™



Builders have discovered that short Cabinet™ screws can sometimes be used in vinyl siding installation, which makes this fastener ideal for both interior and exterior applications.

The Cabinet screw can also be used for light duty framing applications where a smaller diameter shank is necessary, yet a need exists for drawing power delivered by the washer head.

### ADVANTAGES

- **Recessed Star Drive:** Zero Stripping, with 6 points of contact.
- **Washer Head:** Creates a flush, clean hold for a strong and secure installation.
- **W-Cut™:** Low torque, smoother drive, reduce splitting.
- **Zip-Tip™:** No pre-drilling, faster penetration, reduce splitting.
- **Case Hardened Steel:** for high tensile, torque and shear strength.
- **Climatek™ Coating** is AC257 code approved for use in treated lumber.
- For interior/exterior use.

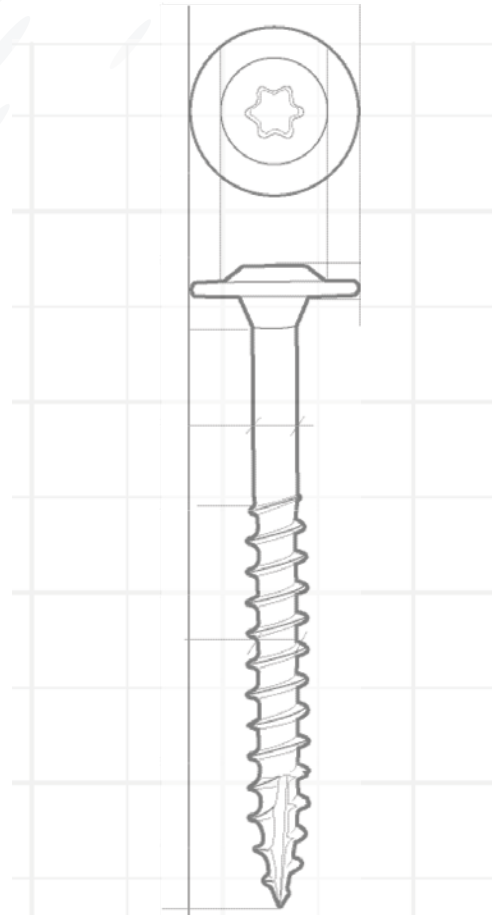

### APPROVALS/LISTING



## Low Profile Cabinet™ Screws

### SELECTION CHART



U.S. (STD.) SIZE (DIA. X LENGTH)	METRIC SIZE (DIA. X LENGTH)	BULK PART NO.	BULK BOX QTY.	HANDY-PAK PART NO.	HANDY-PAK CTN. SIZE/QTY.
#8 x 1"	4.0 x 25			12067	S/100
#8 x 1-1/4"	4.0 x 30	10069	4,000	12069	S/100
#8 x 1-1/2"	4.0 x 40			12073	M/100
#8 x 1-3/4"	4.0 x 45			12075	M/100
#8 x 2"	4.0 x 50			12077	M/100
#8 x 2-1/2"	4.0 x 63			12079	M/100



***Ideal for Cabinets...and so much more. Also excellent for a variety of interior or exterior jobs.***



**NOTE:** 1" bits in Handy-Paks.

**For Plumb  
Installation of  
Wooden Doors  
and Windows.  
No More Shims!**



**DESCRIPTION/SUGGESTED SPECIFICATIONS**

**Adjustable Shim Screws—**

GRK's adjustable Top Star™ shim screw, is in fact a screw within a screw that allows you to install wooden doors or windows without the use of shims.

**ÜberGrade™**



Door stop or cover caps will hide hole

The quick and easy system reduces labour and allows for hassle free adjustment to ensure plumb installation.

Our product is suited to meet the needs of both professional contractors and weekend warriors making the job easier for one person.

Fine adjustments are as simple as the turn of a screw, even after years of use and settling.

**ADVANTAGES**

- **Recessed Star Drive:** Zero Stripping, with 6 points of contact.
- **4-point 3/8" diameter Threaded Sleeve** provides a secure hold on your wooden frame.
- **Micro-Adjustments** allow for an absolutely plumb installation.
- Use with GRK's **Top Star™ Crown** and **T-15 Star bit system**.
- **White Zinc Plated** finish for lasting durability.
- **For Shim Free installation** of wooden doors, windows, insulation, paneling, built-in wall units and cabinets.

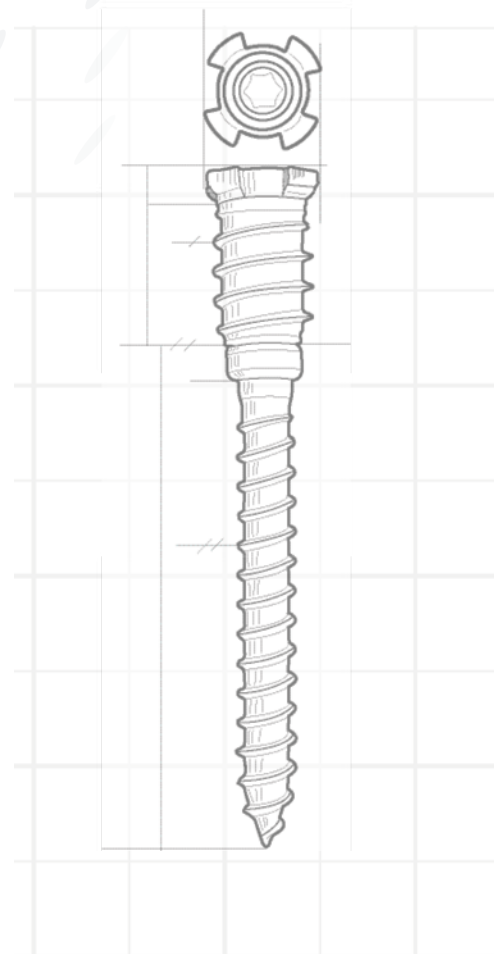



## Top Star™ Adjustable Shim Screws

### SELECTION CHART

U.S. (STD.) SIZE (DIA. X LENGTH)	METRIC SIZE (DIA. X LENGTH)	BULK PART NO.	BULK BOX QTY.	BLISTER-PAK PART NO.	BLISTER-PAK QTY.
3/8" x 2-1/2"	6.0 x 63	20157	100	24050	6
3/8" x 3-1/8"	6.0 x 80	20161	100	24100	6
<b>CROWN / BIT</b>					
Includes: (1) Crown / Bit with each				86465	1



*The Bit drives the Top Star™ into the material when the Crown and Bit are combined. Using the Bit without the Crown adjusts the distance.*

*The Threaded Sleeve moves independently from the Top Star™ unless locked by the Crown. When locked, the Top Star™ gets driven into the material. Unlocked, the installed Top Star™ is ready for levelling.*

### The Complete Top Star™ System Includes:

**BIT**

**CROWN**

**THREADED SLEEVE**

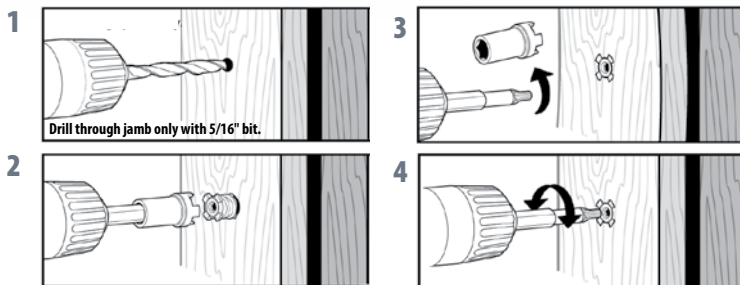

**NOTE:** Crown and Star bit system included in each bulk box. 5/16" drill bit not included.



### Heavy Duty Concrete and Masonry Fastener



#### DESCRIPTION/SUGGESTED SPECIFICATIONS

##### Concrete Screws—

Caliburn™ Concrete screws are professionally engineered fasteners with a patented thread design for ease of driving the screw in concrete and similar applications.

##### ÜberGrade™

Available in three different head designs for multiple applications. Caliburn™, Caliburn™ PH and Caliburn™ XL are Climatek™ coated for high corrosion resistance.



Caliburn's uncompromised draw and pullout strength make it possible to be used in jobs which previously required an anchor. The screws aggressive thread design afford it the ability to be removed and reinserted into the same pilot hole numerous times—without the concern of the fastener breaking or the threads wearing.

#### ADVANTAGES

- **Recessed Star Drive:** Zero Stripping, with 6 points of contact.
- **Aggressive Heavy duty threads** lock into concrete and can be removed and reinserted without screw damage.
- **Countersinking Bugle Head** locks wood to concrete for complete installation and effective anchoring.
- **Caliburn™ PH** pan head, which is ideal for an exposed finished look including installation of electrical boxes.
- **Caliburn™ XL** washer head design for superior holding power.
- **Climatek™ Coating** is AC257 code approved for use in treated lumber.
- Ideal for use in anchoring to concrete or wood to concrete applications including basement framing and sheds.

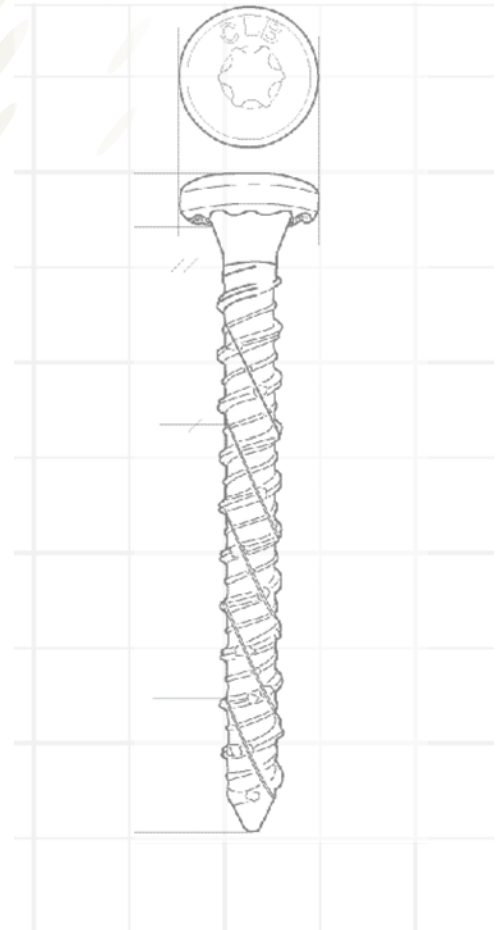

#### APPROVALS/LISTING



## Caliburn™ Concrete Screws

### SELECTION CHART



T-30



T-30



T-40

U.S. (STD.) SIZE (DIA. X LENGTH)	METRIC SIZE (DIA. X LENGTH)	HANDY-PAK PART NO.	HANDY-PAK CTN. SIZE/QTY.
1/4" x 1-3/4"	6.0 x 45	57153	M/50
1/4" x 2-1/4"	6.0 x 55	57156	M/50
1/4" x 2-3/4"	6.0 x 70	57159	M/50
1/4" x 3-1/2"	6.0 x 90	57163	M/50
<b>CALIBURN™ PH</b>			
1/4" x 2-1/4"	6.0 x 55	57831	M/50
<b>CALIBURN™ XL</b>			
19/64" x 2-3/4"	7.5 x 70	57774	M/25
19/64" x 3-1/2"	7.5 x 90	57778	M/25
19/64" x 5"	7.5 x 125	57785	M/25

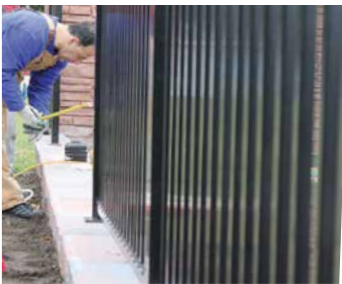

**Great for a wide variety of indoor / outdoor home renovation projects**

1" bits in Handy-Paks.

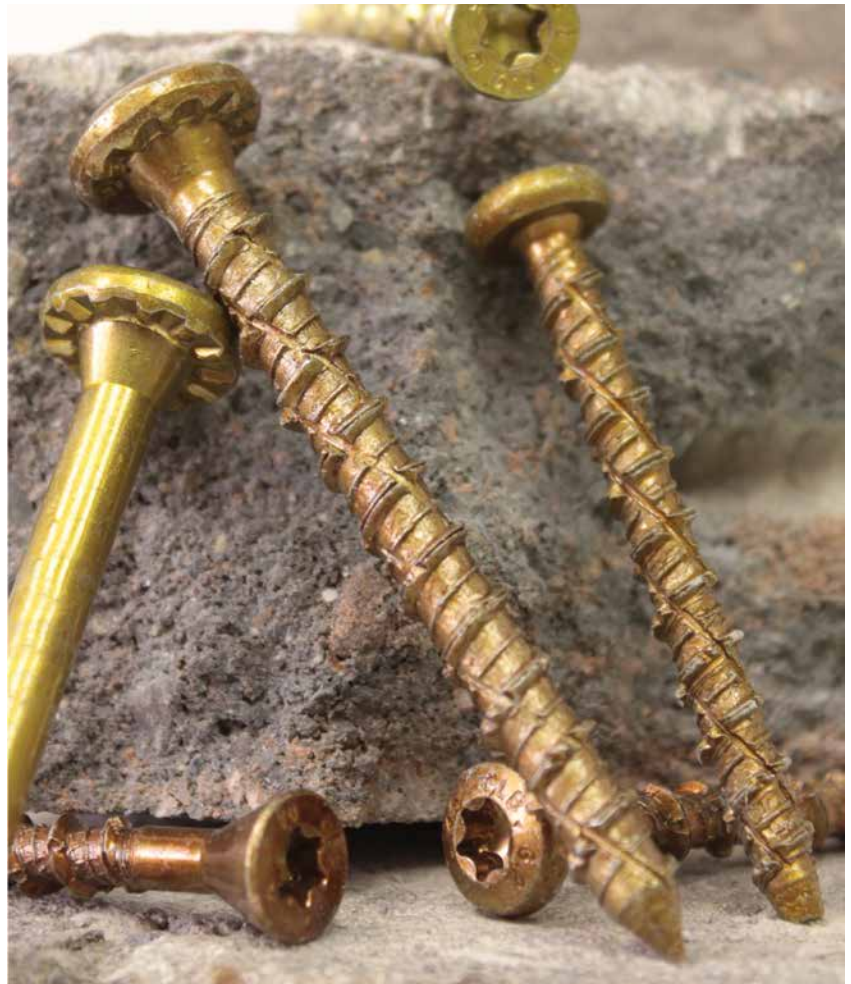

## Star Drive Bits, Crown/Bit and Magnetic Bit Holder



BIT SIZE	BIT COLOUR	FITS	CARDED PART NO.	CARDED QTY/PER PACK	BOX PART NO.	QTY/BOX
T-10 2"	yellow	Trim™ Head #8	87419	2		
T-15 2"	red	R4™ Screw #6 & 8 Trim™ Head #9 Cabinet™ Screw Vinyl Window #8	87427	2		
T-20 2"	purple	Kameleon™ Screws	87435	2		
T-25 2"	green	R4™ #9,10 &12, Caliburn™, Caliburn PH™, RSS™ #10 & 1/4"	87443	2	86443	1,000
T-30 2"	black	RSS™ Structural Screw 5/16" & 3/8", Caliburn™ & Caliburn PH™	87451	2	86451	1,000
T-40 2"	blue	Caliburn XL™ Screws RSS™ Structural Screw 3/8"	87459	2	86459	1,000
<b>CROWN/BIT</b>						
		TOP STAR™	86465	1		

## High Impact Merchandisers Designed to Drive Sales

Displays are free with qualifying order.

### Universal Display:

Ideal for end-cap with large selection of GRK product.

### Heavy Duty Rack Display:



## PERFORMANCE TABLES

TABLE 1: RSS™ FASTENER SPECIFICATIONS

FASTENER DESIGNATION	OVERALL LENGTH <sup>1</sup> (INCHES)	LENGTH OF THREAD <sup>2</sup> (INCHES)	MINOR THREAD DIAMETER <sup>3</sup> (INCHES)	SHANK DIAMETER <sup>3</sup> (INCHES)	OUTSIDE THREAD DIAMETER <sup>3</sup> (INCHES)	ALLOWABLE STEEL STRENGTH										
						BENDING YIELD STRENGTH <sup>4</sup> F <sub>YB</sub> (PSI)	TENSILE (LBF)	SHEAR (LBF)								
RSS	1/4 x 2-1/2"	2-3/8	1-1/2	0.152	0.169	0.236	170,400	<b>1,112</b>	<b>754</b>							
	1/4 x 2-3/4"	2-3/4	1-3/4													
	1/4 x 3-1/8"	3-1/8	2													
	1/4 x 3-1/2"	3-1/2	2-3/8													
RSS	5/16 x 2-1/2"	2-3/8	1-1/2	0.167	0.195	0.276	190,900	<b>1,415</b>	<b>982</b>							
	5/16 x 2-3/4"	2-3/4	1-3/4													
	5/16 x 3-1/8"	3-1/8	2-1/8													
	5/16 x 3-1/2"	3-1/2	2-1/2													
	5/16 x 4"	3-7/8	2-3/4													
	5/16 x 5-1/8"	5	3-1/2													
	5/16 x 6"	5-7/8	3-7/8													
	RSS	3/8 x 3-1/8"	3-1/8							2-1/8	0.191	0.219	0.313	178,000	<b>1,941</b>	<b>1,231</b>
		3/8 x 4"	3-7/8							2-3/4						
		3/8 x 5-1/8"	5-1/8							3-1/2						
3/8 x 6"		5-7/8	4													
3/8 x 7-1/4"		7	4-1/2													
3/8 x 8"		7-7/8	4-3/8													
3/8 x 10"		9-3/4	5													
3/8 x 12"		11-7/8	5-7/8													
3/8 x 14-1/8"		14-1/8	5-7/8													
3/8 x 16"		15-5/8	5-3/4													
LFT	3/8 x 8"	7-7/8	3-7/8	0.191	0.220	0.310	167,600	<b>1,714</b>	<b>1,094</b>							
	3/8 x 10"	9-7/8	3-7/8													
	3/8 x 12"	11-3/4	3-7/8													
	3/8 x 15"	14-3/4	3-7/8													
	3/8 x 20"	19-5/8	3-7/8													
JTS	1/4 x 3-3/8"	3-3/8	1-3/8	0.152	0.171	0.240	226,300	<b>1,104</b>	<b>769</b>							
	1/4 x 5"	5	1-5/8													
	1/4 x 6-3/4"	6-3/4	1-1/2													

for S1: 1 inch = 25.4 mm; 1 psi = 6.9 kPa.

<sup>1</sup> Overall length of fastener is measured from the underside of the head to bottom of the tip. See Figure 1.

<sup>2</sup> Length of thread includes tip. See detailed illustration, Figure 1.

<sup>3</sup> Minor thread, shank and outside thread diameters are shown in table without manufacturing tolerances.

<sup>4</sup> Bending yield strength determined in accordance with ASTM F 1575 using the minor thread diameter.

## PERFORMANCE TABLES

**TABLE 2: RSS™ WITHDRAWAL DESIGN VALUES (W)<sup>1</sup>**  
**[WITHDRAWAL VALUES (W) ARE IN POUNDS PER INCH OF THREAD PENETRATION INTO SIDE GRAIN OF MAIN MEMBER]**

FASTENER DESIGNATION AND DIAMETER Ø		WITHDRAWAL, W (LBS./IN.) FOR SPECIFIC GRAVITIES OF:	
		0.42 ≤ G < 0.55	0.55 ≤ G < 0.67
RSS	Ø 1/4	151	186
	Ø 5/16	165	227
	Ø 3/8	180	259
LTF	Ø 3/8	163	216
JTS	Ø 1/4	152	191

for S1: 1 inch = 25.4 mm

<sup>1</sup> Fastener withdrawal was tested in accordance with ASTM D 1761.

<sup>2</sup> Withdrawal values (W) shall be multiplied by the length of thread penetration in the main member (including tip).

**TABLE 3: RSS™ PULL-THROUGH DESIGN VALUES (P)<sup>1</sup>**  
**[PULL-THROUGH VALUES (P) ARE IN POUNDS PER INCH OF SIDE MEMBER THICKNESS]**

FASTENER DESIGNATION AND DIAMETER Ø		PULL-THROUGH, P (LBS./IN.) FOR SPECIFIC GRAVITIES OF:	
		0.42 ≤ G < 0.55	0.55 ≤ G < 0.67
RSS	Ø 1/4	165	275
	Ø 5/16	207	418
	Ø 3/8	196	351
LTF	Ø 3/8	202	373
JTS	Ø 1/4	154	372

for S1: 1 inch = 25.4 mm

<sup>1</sup> Fastener pull-through testing was performed in accordance with ASTM D 1037 with 3/4" thick side members.

**These figures are only offered as a guide and are not reduced by any safety factor. For safety factor requirements in your area, contact your local building official, architect or engineer.**

## PERFORMANCE TABLES

**TABLE 4: RSS™ LATERAL DESIGN VALUES (Z) FOR SINGLE SHEAR (TWO-MEMBER) CONNECTIONS<sup>1</sup>**  
**[FOR SAWN LUMBER OR SCL WITH BOTH MEMBERS OF IDENTICAL SPECIFIC GRAVITY]**

FASTENER DESIGNATION	SIDE MEMBER THICKNESS $T_s$ (INCHES):	FASTENER PENETRATION $P$ (INCHES)	LATERAL VALUE, Z (POUNDS) FOR SPECIFIC GRAVITIES OF:			
			$0.42 \leq G < 0.55$		$0.55 \leq G < 0.67$	
			PARALLEL TO GRAIN $Z_{\parallel}$	PERPENDICULAR TO GRAIN, $Z_{\perp}$	PARALLEL TO GRAIN $Z_{\parallel}$	PERPENDICULAR TO GRAIN, $Z_{\perp}$
RSS	1/4 x 2-1/2"	3/4	153	137	175	175
	1/4 x 2-3/4"	3/4				
	1/4 x 3-1/8"	3/4				
	1/4 x 3-1/2"	3/4				
	5/16 x 2-1/2"	3/4	168	133	214	178
	5/16 x 2-3/4"	3/4				
	5/16 x 3-1/8"	3/4				
	5/16 x 3-1/2"	3/4				
	5/16 x 4"	1-1/2	239	236	333	257
	5/16 x 5-1/8"	1-1/2				
	5/16 x 6"	2	265	299	472	289
	3/8 x 3-1/8"	3-4	188	156	251	220
	3/8 x 4"	1-1/2	224	205	274	264
	3/8 x 5-1/8"	1-1/2				
	3/8 x 6"	2	270	296	325	288
	3/8 x 7-1/4"	2-3/4	423	291	593	304
	3/8 x 8"	3-1/2				
	3/8 x 10"	3-1/2				
3/8 x 12"	3-1/2					
3/8 x 14-1/8"	3-1/2					
3/8 x 16"	3-1/2					
LFT	3/8 x 8"	4	433	315	556	402
	3/8 x 10"	6				
	3/8 x 12"	8				
	3/8 x 15"	11	N/A	N/A	N/A	N/A
	3/8 x 20"	16	N/A	N/A	N/A	N/A
JTS	1/4 x 3-3/8"	1-3/4	157	168	217	217
	1/4 x 5"	1-3/4	168	221	241	237
	1/4 x 6-3/4"	1-3/4				

for S1: 1 inch = 25.4 mm

<sup>1</sup> Lateral load testing was performed in accordance with ASTM D 1761.

These figures are only offered as a guide and are not reduced by any safety factor. For safety factor requirements in your area, contact your local building official, architect or engineer.



## PERFORMANCE TABLES

TABLE 5: CONNECTION GEOMETRY

CONNECTION GEOMETRY/CRITERIA	DIAMETERS <sup>1</sup>	RSS & JTS 1/4" NOMINAL DIAMETER (INCHES)	RSS 5/16" NOMINAL DIAMETER (INCHES)	RSS & LTF 3/8" NOMINAL DIAMETER (INCHES)
<b>MINIMUM EDGE DISTANCE</b>				
LOADING PARALLEL TO GRAIN	8	1-1/2	1-5/8	1-7/8
LOADING PERPENDICULAR TO GRAIN, LOADED EDGE	8	1-1/2	1-5/8	1-7/8
LOADING PERPENDICULAR TO GRAIN, UNLOADED EDGE	8	1-1/2	1-5/8	1-7/8
<b>MINIMUM END DISTANCE</b>				
TENSION LOAD PARALLEL TO GRAIN	15	2-5/8	3	3-3/8
COMPRESSION LOAD PARALLEL TO GRAIN	10	1-3/4	2	2-1/4
LOAD PERPENDICULAR TO GRAIN	10	1-3/4	2	2-1/4
<b>SPACING (PITCH) BETWEEN FASTENERS IN A ROW</b>				
PARALLEL TO GRAIN	15	2-5/8	3	3-3/8
PERPENDICULAR TO GRAIN	10	1-3/4	2	2-1/4
<b>SPACING (GAGE) BETWEEN ROWS AND FASTENERS</b>				
IN-LINE	5	7/8	1	1-1/8
STAGGERED	2.5	1/2	1/2	5/8
<b>MINIMUM PENETRATION INTO MAIN MEMBER FOR SINGLE SHEAR CONNECTIONS</b>				
	6 <sup>2</sup>	1-1/8	1-1/4	1-3/8

for S1: 1 inch = 25.4 mm

<sup>1</sup> Diameter is the shank diameter as specified in Table 1.

<sup>2</sup> Reduce lateral load values provided in Table 4 when penetration is less than 10D.

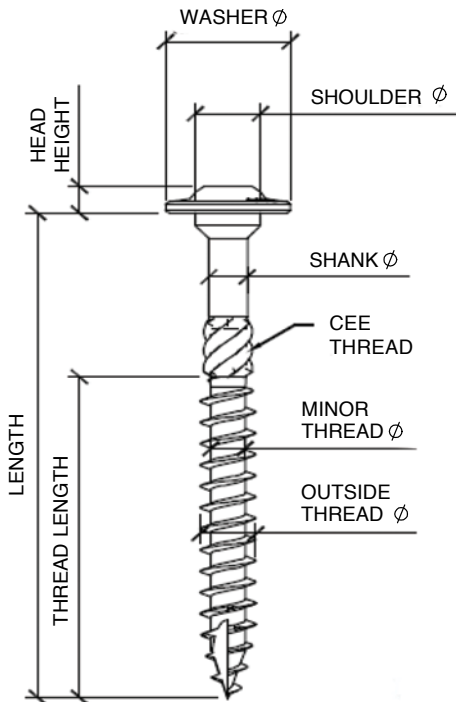

FIGURE 1 - FASTENER DIMENSIONS

SCREW TYPE	HEAD STAMP	WASHER Ø ± 0.020	HEAD HEIGHT ± 0.010	SHOULDER Ø ± 0.010	CEE THREAD <sup>2</sup>
RSS 1/4 (6.0 mm)		0.533	0.110	0.244	LENGTH ≥ 3-1/8"
RSS 5/16 (7.0 mm)		0.620	0.157	0.301	LENGTH ≥ 3-1/8"
RSS 3/8 (8.0 mm)		0.689	0.181	0.364	LENGTH ≥ 3-1/8"
LTF 3/8 (8.0 mm)		0.688	0.181	0.364	LENGTH ≥ 3-1/8"
JTS 1/4 (6.3 mm)		0.534	0.090	0.244	LENGTH ≥ 5"

**NOTES:**

1. See table 1 for overall length, thread length, shank diameter, outside thread diameter and minor thread diameter.
2. CEE thread on screws with lengths greater than or equal to those indicated, not used for calculations.

## PERFORMANCE TABLES

TABLE 1: FASTENER SPECIFICATIONS

FASTENER DESIGNATION	OVERALL LENGTH <sup>1</sup> (INCHES)	LENGTH OF THREAD <sup>2</sup> (INCHES)	MINOR THREAD DIAMETER <sup>3</sup> (INCHES)	SHANK DIAMETER <sup>3</sup> (INCHES)	OUTSIDE THREAD DIAMETER <sup>3</sup> (INCHES)	ALLOWABLE STEEL STRENGTH			
						BENDING YIELD STRENGTH <sup>4</sup> F <sub>yb</sub> (PSI)	TENSILE (PSI) [POUNDS]	SHEAR (PSI) [POUNDS]	
R4	9 x 2"	2	1-1/4	0.117	0.130	0.174	158,800	<b>61,760</b> [627]	<b>39,660</b> [428]
	9 x 2-1/2"	2-3/8	1-5/8						
	9 x 2-3/4"	2-3/4	1-7/8						
	9 x 3-1/8"	3-1/8	2-1/8						
	10 x 2-1/2"	2-3/8	1-5/8	0.128	0.142	0.194	143,590	<b>62,640</b> [846]	<b>44,520</b> [542]
	10 x 2-3/4"	2-3/4	1-7/8						
	10 x 3-1/8"	3-1/8	2-1/8						
	10 x 3-1/2"	3-1/2	2-3/8						
	10 x 4"	3-7/8	2-5/8						
	10 x 4-3/4"	4-5/8	3	0.153	0.172	0.238	134,280	<b>60,580</b> [1,134]	<b>38,610</b> [655]
	12 x 2-1/2"	2-3/8	1-1/2						
	12 x 2-3/4"	2-3/4	1-3/4						
	12 x 3-1/8"	3-1/8	2-1/8						
	12 x 3-1/2"	3-1/2	2-3/8						
	12 x 4"	3-7/8	2-5/8						
	12 x 4-3/4"	4-5/8	3						
12 x 5-5/8"	5-1/2	3							
12 x 6-3/8"	6-1/4	3							
12 x 7-1/4"	7	3							
12 x 8"	7-7/8	2-5/8							
12 x 10"	9-3/4	2-3/4							
12 x 12"	11-3/4	2-3/4							
TRIM	8 x 2-1/2"	2-3/8	1-1/2	0.106	0.116	0.160	148,410	<b>56,580</b> [499]	<b>40,000</b> [360]
	8 x 2-3/4"	2-3/4	1-7/8						
	8 x 3-1/8"	3-1/8	2-1/8						
	9 x 2-1/2"	2-3/8	1-5/8	0.114	0.128	0.176	147,280	<b>57,000</b> [576]	<b>42,160</b> [425]
	9 x 2-3/4"	2-3/4	1-3/4						
	9 x 3-1/8"	3-1/8	2-1/8						
KAMELEON	9 x 2-1/2"	2-1/2	1-5/8	0.119	0.134	0.177	160,210	<b>57,490</b> [634]	<b>37,870</b> [437]
	9 x 2-3/4"	2-3/4	1-3/4						
	9 x 3-1/8"	3-1/8	2-1/8						

for S1: 1 inch = 25.4 mm; 1 psi = 6.9 kPa.

<sup>1</sup> Overall length of fastener is measured from the top of the head to bottom of the tip. See Figure 1.

<sup>2</sup> Length of thread includes tip. See detailed illustration, Figure 1.

<sup>3</sup> Minor thread, shank and outside thread diameters are shown in table without manufacturing tolerances.

<sup>4</sup> Bending yield strength determined in accordance with ASTM F 1575 using the minor thread diameter.

# R4™, Trim™, Kameleon™ Technical Fastener Data

## PERFORMANCE TABLES

SCREW TYPE	HEAD Ø	CEE-THREAD
R4 - #9 (4.5 mm)	0.328 ± 0.006	LENGTH = > 2"
R4 - #10 (5.0 mm)	0.368 ± 0.006	LENGTH = > 2"
R4 - #12 (6.0 mm)	0.439 ± 0.010	LENGTH = > 2"
TRIM - #8 (4.0 mm)	0.197 ± 0.006	N/A
TRIM - #9 (4.5 mm)	0.230 ± 0.006	N/A
KAMELEON - #9 (4.5 mm)	0.258 ± 0.006	ALL LENGTHS

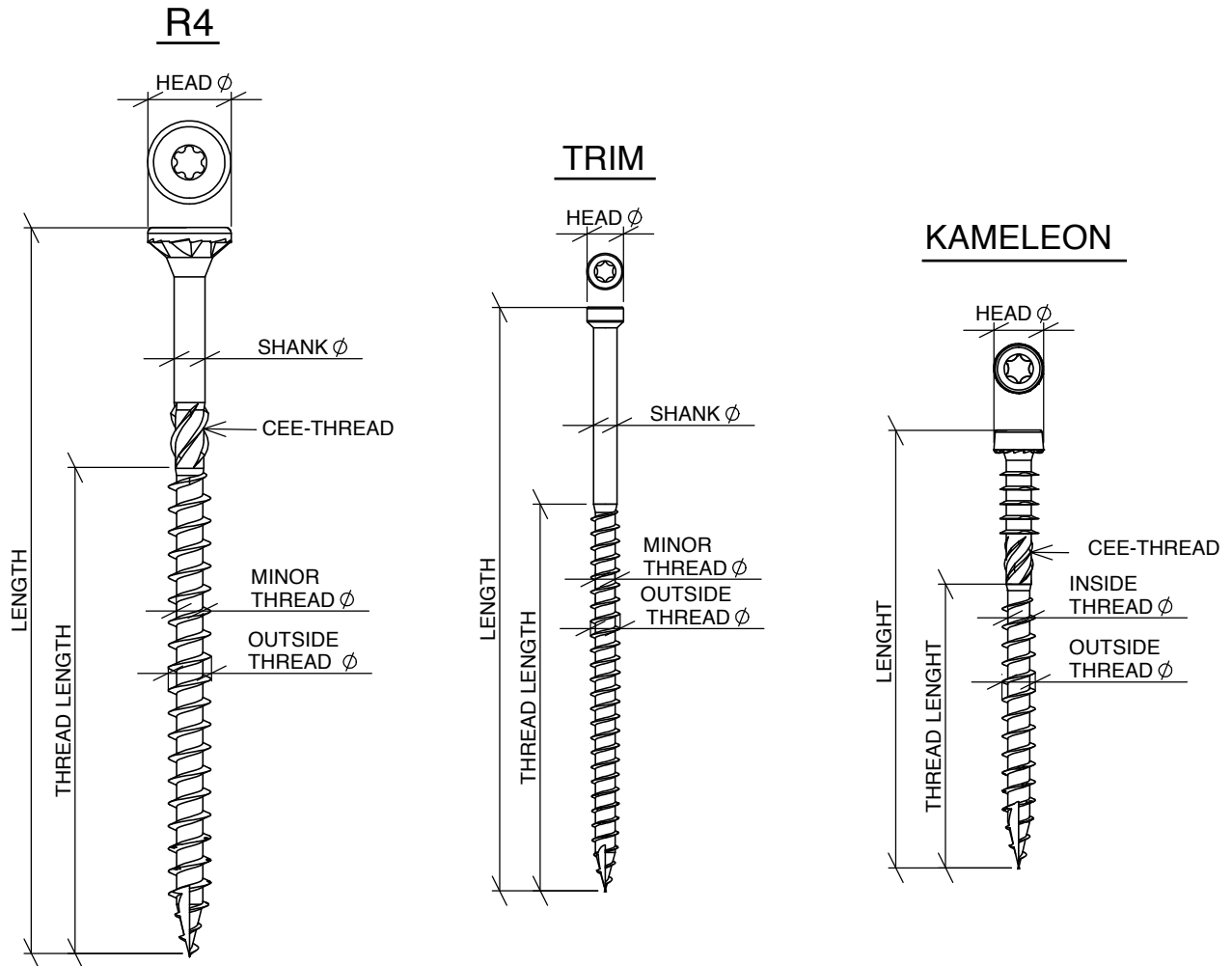

FIGURE 1 - FASTENER DIMENSIONS

### NOTES:

1. See table 1 for overall length, thread length, shank diameter, outside thread diameter and minor thread diameter.
2. CEE thread on screws with lengths greater than or equal to those indicated, not used for calculations.
3. Dimensions given if not otherwise stated are in inches (for SI 1 inch = 25.4 mm)

## PERFORMANCE TABLES

**TABLE 2: DESIGN WITHDRAWAL VALUES (W)<sup>1</sup>**  
**[TABULATED WITHDRAWAL VALUES (W) ARE IN POUNDS PER INCH OF THREAD PENETRATION INTO SIDE GRAIN OF MAIN MEMBER]**

FASTENER DESIGNATION		WITHDRAWAL, W (LBS./IN.) FOR SPECIFIC GRAVITIES OF:
		0.67
R4	# 9	179
	# 10	249
	#12	255
TRIM	# 8	175
	# 9	221
KAMELEON	# 9	186

for S1: 1 inch = 25.4 mm; 1 lbf/in = 175.127 N/m.

<sup>1</sup> Fastener withdrawal was tested in accordance with ASTM D 1761.

<sup>2</sup> Values must not be multiplied by any adjustment/safety factor.

**TABLE 3: DESIGN PULL-THROUGH VALUES (P)<sup>1</sup>**  
**(TABULATED PULL-THROUGH VALUES (P) ARE IN POUNDS PER INCH OF SIDE MEMBER THICKNESS)**

FASTENER DESIGNATION		PULL-THROUGH, P (LBS./IN.) FOR SPECIFIC GRAVITIES OF:
		0.67
R4	# 9	162
	# 10	275
	#12	407
TRIM	# 8	61
	# 9	94
KAMELEON	# 9	143

for S1: 1 inch = 25.4 mm; 1 lbf/in = 175.127 N/m.

<sup>1</sup> Fastener pull-through testing was performed in accordance with ASTM D 1037.

<sup>2</sup> Values must be multiplied by all applicable adjustment factors. (20.15 NDS Table 11.3.1)

<sup>3</sup> Minimum side member thickness must be 3/4".

# R4™, Trim™, Kameleon™ Technical Fastener Data

## PERFORMANCE TABLES

**TABLE 4: REFERENCE LATERAL DESIGN VALUES (Z) FOR SINGLE SHEAR (TWO MEMBER) CONNECTIONS<sup>1</sup>**  
**[FOR SAWN LUMBER OR SCL WITH BOTH MEMBERS OF IDENTICAL SPECIFIC GRAVITY]**

	FASTENER DESIGNATION	SIDE MEMBER THICKNESS, $T_5$ (INCHES)	FASTENER PENETRATION, $P$ (INCHES)	REFERENCE LATERAL ULTIMATE VALUE, $Z$ (POUNDS) FOR SPECIFIC
				0.67
				PARALLEL TO GRAIN, $Z_{  }$
R4	9 x 2"	3/4	1-1/8	175
	9 x 2-1/2"	3/4	1-1/2	
	9 x 2-3/4"	3/4	2	
	9 x 3-1/8"	3/4	2-3/8	
	10 x 2-1/2"	3/4	1-1/2	203
	10 x 2-3/4"	3/4	2	
	10 x 3-1/8"	3/4	2-3/8	
	10 x 3-1/2"	3/4	2-3/4	
	10 x 4"	3/4	3-1/8	242
	10 x 4-3/4"	3/4	3-7/8	
	12 x 2-1/2"	3/4	1-1/2	
	12 x 2-3/4"	3/4	2	
	12 x 3-1/8"	3/4	2-3/8	
	12 x 3-1/2"	3/4	2-3/4	
	12 x 4"	3/4	3-1/8	
	12 x 4-3/4"	3/4	3-7/8	
	12 x 5-5/8"	3/4	4-3/4	
	12 x 6-3/8"	3/4	5-1/2	
	12 x 7-1/4"	3/4	6-1/4	
	12 x 8"	3/4	7	
12 x 10"	3/4	9		
12 x 12"	3/4	11		
TRIM	8 x 2-1/2"	3/4	1-1/2	84
	8 x 2-3/4"	3/4	2	
	8 x 3-1/8"	3/4	2-1/2	
	9 x 2-1/2"	3/4	1-1/2	104
	9 x 2-3/4"	3/4	2	
	9 x 3-1/8"	3/4	2-3/8	
KAMELEON	9 x 2-1/2"	3/4	1-5/8	159
	9 x 2-3/4"	3/4	1-7/8	
	9 x 3-1/8"	3/4	2-3/8	

for S1: 1 inch = 25.4 mm

<sup>1</sup> Lateral load testing was performed in accordance with ASTM D 1761.

<sup>2</sup> Values must be multiplied by all applicable adjustment factors. (20.15 NDS Table 11.3.1)



## LIABILITY AND WARRANTIES

GRK Fasteners™ is a distributor of commercial grade fasteners. Conformance to “IFI” specifications is formally requested from our suppliers. The parts that we supply are quality inspected by independent labs.

We maintain lot traceability on all products listed in this catalog as long as they are in their original bulk boxes. Certifications are maintained on all fasteners.

**Hydrogen Embrittlement:** We require our platers and suppliers of plated fasteners to bake case hardened parts to “IFI” specifications. However, this process does not guarantee that hydrogen embrittlement will not still be present after baking or that it will not occur at a later date while in service. Specialized testing or a substitute part may be required, depending on the application.

**Liability:** Claims against GRK Fasteners™ shall be limited to a refund or credit for the price billed or paid for faulty or incorrect merchandise. Seller shall not be responsible for buyer's manufacturing costs, labour, alternate purchases, extra freight, replating, plating, lost profit, good will, recall costs, or other incidental or consequential damages.

**Warranties:** GRK Fasteners™ (“GRK”) warrants to the first retail purchaser that its Climatek™ coated will not rust under normal environmental conditions when used in accordance with the recommendations listed in GRK's Screw Selection Guide. This warranty is not transferable.

**Refunds:** In order to receive a refund, the customer must return to us at least 50 of the defective screws (including screw heads) for verification.

**THERE ARE NO UNDERSTANDINGS, AGREEMENTS, REPRESENTATIONS OR ADDITIONAL WARRANTIES, EXPRESSED OR IMPLIED (INCLUDING ANY REGARDING WARRANTIES OF MERCHANTABILITY OR FITNESS FOR A PARTICULAR PURPOSE), NOT SPECIFIED HEREIN, RESPECTING ANY SALE OF PRODUCTS BY GRK FASTENERS™, (TO THE EXTENT PERMITTED BY LAW).**



## **National Headquarters**

120 Travail Road  
Markham, Ontario, L3S 3J1

Tel: 905-471-7403  
800-387-9692

Fax: 905-471-7208  
800-668-8688

## **Technical and Customer Service Support**

Tel: 800-387-9692

Fax: 800-668-8688

## **Regional Warehouses**

- Markham, Ontario
- Coquitlam, British Columbia
- Calgary, Alberta

## **Take Advantage of these Contractor Services from ITW Construction Products Canada**

From job sites to engineering firms, from Safety Seminars to on-site services, we hope you take advantage of our many contractor services— at no charge! After all, it's one thing to offer the quality products you need to do your job. It's another to provide you with superior service, engineering expertise and total product support.

At ITW Construction Products Canada, we are proud of the partnerships we have built through the years with our distributor network and contractors. Thanks to quality products, innovative services and on-time delivery, we will continue to build new relationships and strengthen existing ones today... and into the next century.

- Factory representatives with years of training and service experience will go out to your job site to provide you with product, service and technical assistance.
- We provide architects and engineers with complete submittal packages which gives them the technical data needed to specify ITW Construction Products Canada products. Contact your ITW Construction Products Canada Distributor or your nearest Customer Service location to request submittal packages.

## **Technical Application Assistance:**

- Our staff of application specialists are ready to assist you with any type of application or code approval question during any phase of your project. Call 1-800-387-9692 between 8:00 a.m. and 5:00 p.m. EST, Monday through Friday.

## **Distributed By**

Ramset, T4, T3, T3Cup, Trakfast, GypFast, Mastershot, Triggershot, Hammershot, PowerPoint, TE Pin and Climacoat are trademarks of Illinois Tool Works, Inc.

A7+, C6+, Dynabolt, G5, Hammer-Set, LDT, Multi-Set II, Poly Set, Red Head, Redi-Drive, S7, Striker, and Trubolt are trademarks of ITW Red Head and Illinois Tool Works, Inc.

Teks, TruGrip GT, Scots, Maxiseal, Dek-Cap, Tapcon, SG, Tapcon, Maxi-Set Tapcon, Condrive, E-Z Ancor, E-Z Toggle, Twist-N-Lock, E-Z Lite, E-Z Mini, Stud Solver, Hi-Lo, S-12, Backer-On, Rock-On, Decking, Dec-U-Drive, Dek-Cap, Grid-Mate, Grid-Mate, PB, Climaseal, Spex, Climacoat, UltraShield, Climashield and Building Ideas That Work are trademarks of ITW Buildex and Illinois Tool Works, Inc.

Sammys, Sammy X-Press, Sammy X-Press It, Sammy X-Press Swivel, Sammy X-Press Sidewinder, Tapcon, Sammy Saddle, Speedy Pole Tool, Spot-Rite Level, and Truss-T Hanger are trademarks of ITW Buildex and Illinois Tool Works, Inc.

The term "Paslode" is a trademark and the Paslode logo and all related product and service names, designs and slogans are Paslode trademarks. Paslode, RounDrive, Impulse, Positive Placement are registered trademarks, PowerFramer and quicklode are trademarks of Illinois Tool Works.

R4, Deck Elite, RSS, Kameleon, Fin/Trim, RT Composite, Low Profile Cabinet, Pheinox, Top Star, VWS, Caliburn, and The GRK Fasteners Canada Ltd. and all associated designs and logos are trademarks of GRK Fasteners Canada Ltd., used under license.

Hilti is a registered trademark of Hilti, Corp.

DensGlass is a registered trademark of Georgia Pacific Building Products.

Dekstrip, Dektite, Retrofit Dektite, and Dektite are registered trademarks of Deks Industries Pty Ltd.

Phillips Square-driv is a registered trademark of the Phillips Screw Company.

The information and recommendations in this document are based on the best information available to us at the time of preparation. We make no other warranty, expressed or implied, as to its correctness or completeness, or as to the results or reliance of this document.